

PLATFORM FLOORS
Raised Access Floors

PSA MOB PF2 PS/SPU

Performance Specification

March 1992
(Updated 2020 in conjunction with the AFA)



FOREWORD [2020]

The MOB PF2 PS Specification as released by the PSA in 1992 remains the most comprehensive and pre-eminent classification system for the provision of Raised Access Floors in the UK. Despite the last updates being made back in 1992, the performance grades and method of tests are still highly relevant for today's high performance commercial buildings.

With the demise of the Property Services Agency and the significant passing of time, the guide has become difficult to locate and more importantly outdated (primarily due to updated codes and practices). As a result, the Access Flooring Association (the AFA) took the decision to review and revise the document in order to both make it more readily available, but also to make sure it stood up to the rigours of current legislation.

This re-edited document is fundamentally in alignment with the original version, it has been re-formatted and any updates have been clearly identified. The revisions have been agreed by the AFA member organisations, which include manufacturers, distributors and independent test facilities. For more information please contact: information@theafa.com

All systems that are tested to PSA MOB PF2 PS are required to be independently tested, verified and certified. It is recommended that this certification is renewed every 5 years.

Platform Floors

(Raised Access Floors)
Performance Specification

PSA Specialist Services

© Crown copyright 1992 (edited & Updated 2020 by the AFA)



Originally devised &
issued by
PSA Specialist Services

PERFORMANCE SPECIFICATIONS

Prepared by Method of Building
PSA Specialist Services
(Original Artwork by MOB Graphics)

CONTENTS

SECTION P	Performance Requirements	5
SECTION T	Methods of Test for Type Approval and Site Quality Control	26
APPENDIX A	Performance and Test Requirements for accessories bar type air grilles	84
APPENDIX B	Project Particulars and Schedule of Performance offer	88

CONTENTS | Section P

PERFORMANCE REQUIREMENTS

P0.00	INTRODUCTION	7
P0.01	Classification	7
P0.02	Definitions	7
P0.03	Evaluation of systems	8
P0.04	Quality assurance	8
P0.05	Not used	9
P0.06	Organisations' responsible for information given	9
P1.00	IDENTIFICATION	9
P1.01	Type and quality	9
P1.02	Purpose and use	9
P1.03	Related documentation	9
P2.00	DESCRIPTION	10
P2.01	Types	10
P2.02	Structural grades	10
P2.03	Constituent materials	10
P2.04	Fixings and fastenings	10
P2.05	Accessories	11
P2.06	Floor coverings - General	11
P2.07	Design and manufacture	11
P3.00	DIMENSIONAL REQUIREMENTS	11
P3.01	Size and dimensional framework	11
P3.02	Panel location	11
P3.03	Gaps between panels	11
P3.04	Damage to services	11
P3.05	Shape: Grid: Dimension: Weight	12
P3.06	Fit	12
P3.07	Overall levels	13
P3.08	Panel levels	13
P3.09	Panel flatness	13
P3.10	Panel squareness	13
P3.11	Panel dimensions	13
P3.12	Panel edge strip	13
P3.13	Panel interchangeability, installation and removal	13
P3.14	Air leakage rate	14
P4.00	STRUCTURAL REQUIREMENTS	14
P4.01	Strength: Grades	14
P4.02	Static loadings and deflection	14
P4.03	Safety factor	14
P4.04	Dynamic loading	15
P4.05	Pedestrian dynamic loading	15
P4.06	Pedestal structure and fixing	15
P4.07	Pedestal stability and strength	16
P4.08	Perimeter details	17
P4.09	Bridging structures	17
P4.10	Safety of the system when panels are removed	17
P4.11	Weight of the system	17
P4.12	Identification of structural grades	17
P4.13	Installation of heavy equipment	17

CONTENTS | Section P

PERFORMANCE REQUIREMENTS

P5.00	HYGROTHERMAL REQUIREMENTS	17
P5.01	Moisture and thermal movement	17
P5.02	Deemed to satisfy the Authority	17
P5.03	Sealing edges of cut panels	18
P6.00	FIRE AND SAFETY REQUIREMENTS	9
P6.01	General	9
P6.02	Spread of flame	9
P6.03	Panel cladding	9
P6.04	Structural materials	9
P6.05	Compliance with tests	9
P6.06	Cavity Barriers	9
P6.07	Perimeter and bridging structure details	9
P6.08	Thermal properties	9
P7.00	TRANSMISSION OF SOUND	9
P8.00	FLOOR COVERINGS	10
P8.01	General	10
P8.02	Coverings for computer suites with full access ventilated floors	10
P8.03	Coverings for areas other than computer suites	10
P8.04	Not used	10
P8.05	Fitting and installation	11
P8.06	Cleaning	11
P9.00	ELECTRICAL REQUIREMENTS	11
P9.01	Electrostatic properties	11
P9.02	Equipotential bonding	11
P9.03	Electrical continuity	11
P10.00	SIDE EFFECTS	14
P10.01	Fungi, moulds and insects	14
P10.02	Toxicity	14
P10.03	Odour	14
P10.04	Vermin	15
P10.05	Creation of dust and harmful contaminants	15
P11.00	DURABILITY	14
P11.01	Life of components	14
P11.02	Protective finishes	14
P12.00	TRANSPORTATION AND STORAGE ON SITE	14
P13.00	SUPPLY AND INSTALLATION	14
P13.01	General	14
P13.02	Working time	14
P13.03	Sealing	14
P13.04	Fire stopping	14
P13.05	Cleaning the void	14
P13.06	Protection of completed work	14
P14.00	TEST EVIDENCE	14

P0.00 | Introduction

This document contains the performance requirements for Platform (Raised Access) structured as follows:

1. Definitions and general conditions
2. Physical design requirements
3. Performance standards

P0.01 Classification

The classification for Platform (Raised Access) Floor System is CI/SfB (33)

P0.02 Definitions

For the purpose of this performance specification, the following definitions apply:

1. The Authority:

The employer named in the Appendix or Abstract of Particulars to the relevant contract or sub-contract or the person nominated to be responsible on his behalf, for the quality of the goods supplied and work executed.

1A. The Supplier:

The contracting organisation offering to design, manufacture or procure and install platform floor systems.

2. Platform Floor System:

The complete raised access floor system comprises load bearing fixed or removable panels supported by adjustable pedestals to provide an underfloor space for the housing and distribution of services etc.

It shall include all necessary accessories, fixings and installation and floor coverings where applicable.

3. Panel:

The complete panel including where applicable, the core material, the metal bottom and top plates or trays, locating devices, edgings, floor coverings, adhesives and fastenings.

4. Pedestal:

The adjustable supporting structure including where applicable, the head complete, base column, adjustment and locking devices.

5. Stringer:

A beam connecting pedestals.

6. Fastenings:

The means of attaching the panels to the pedestals or to the stringer system if applicable.

7. Fixings:

The means of attaching the supporting structure to the sub floor.

8. Dimensions:

- a. Length: One of two horizontal dimensions, normally the greater.
- b. Width: One of two horizontal dimensions, normally the lesser.
- c. Height: Vertical dimension of component parts or system.
- d. Cavity height: Nominal vertical dimension from the sub floor to the lowest part of the panel or supporting structure.
- e. Floor height: Nominal vertical dimension from the sub floor to the finished floor level.
- f. Thickness: A dimension in any plane when its size is small compared with that of any other dimension.

P0.00 | Introduction

9. Basic space:

A space bounded by reference planes, assigned to receive a building component or assembly including the appropriate allowances for joints and tolerance.

Appendix A

10. Co-coordinating size:

A size given to a basic space being width, height or thickness.

11. Work size:

The size of a building component specified for manufacture to which its actual size should conform with specified permissible deviations.

12. Limits of size:

The extreme permissible manufacturing sizes between which the actual size should lie.

13. Tolerance:

The difference between the limits within which a size or position should lie.

14. Deviation:

The difference between a size or position (actual limits etc.) and a specified size or position.

15. Grade:

The loading grade for which the system is designed.

16. Type:

The particular type of system, e.g. partial access, full access, stringer-less or with stringers.

17. Working load:

The load the system or its parts are designed to carry without producing deviations greater than the specified limits. This load can be concentrated or distributed and may be:

- a. Sustained or b. Transient

18. Ultimate load:

The load which will cause failure of the system or its parts. This load can be concentrated or distributed.

19. Factor of Safety:

The ratio between the ultimate load and the working load.

20. Deflection:

The distance the system or its parts move from the original position when subjected to a load.

21. Supplementary supports:

Is taken to mean supports under high loaded areas, around the perimeter, local to columns, access panels etc. which are in addition to the main supporting grid pattern. These may be in the form of pedestals, angles, channels or cross bracings etc.

P0.03

Evaluation of systems

The platform floor systems may be evaluated by the Authority based on experience as well as any test evidence submitted by the supplier. Further tests may be necessary, e.g. where new materials or constructions are involved, or where claimed performance cannot be ascertained by other means. Appearance of platform floor systems will be of importance.

P0.04

Quality assurance

Suppliers are required to operate, as a minimum a quality management system in accordance with ISO9001: 2015 (or the latest version if superseded). Production and Installation certificated by an independent third-party assessor. Provide evidence of status when requested by the Authority. (See Guidance Notes)

P0.00 | Introduction

P0.05 **Not used**

P0.06 **Organisations**

Responsible for information given

This document was originally prepared by:

PSA Specialist Services, Croydon, UK

In Consultation with The Access Flooring Association (updated 2020)

P1.00 | Identification

This document is a statement of the performance requirements for platform floor systems both partial and full access types. A system will include the supply and installation of all components and accessories required to enable it to be fit for the purpose intended and to perform over the period of its designed life to the satisfaction of the Authority.

P1.01 **Type and quality**

The supplier may offer any system which can be shown to satisfy the requirements of this specification with regard to any particular type and grade.

P1.02 **Purpose and use**

The purpose of a platform floor system is to provide a space between it and the structural floor, for the housing and distribution of services. It will be used in the works described in the project particulars.

P1.03 **Related documentation**

The floor systems, their components and accessories etc., shall comply with any British Standard Specification, Code of Practice and statutory requirement relevant to their performance, constituent materials, method of assembly fixing and use.

Any requirement of this specification that any material or article shall comply with any specified standard, whether a BS or other named standard, shall be satisfied by compliance with any equivalent national standard of any Member State of the European Community, or any equivalent international standard recognised in such a Member State.

A supplier offering a product based on compliance with any such standard may be required to provide, in English, technical or other details of the standard and its qualifying tests.

Where there is doubt or conflict, the decision of the Authority shall be sought as early as possible.

P2.00 | Description

P2.01

Types

This specification relates to the following types of platform floor:

- a. Partial access with or without stringers or joists which is a load bearing fixed deck supported on adjustable pedestals and having either runs of removable panels or individual access traps.
- b. Full access with or without stringers which is a deck comprising removable load bearing panels, most of which are interchangeable, supported on adjustable pedestals. The stringers, if incorporated, may be removable.

P2.02

Structural grades

This specification relates to the following structural grades and the supplier may offer any type which complies with a particular grade.

Structural Grade:

- Light Structural Grade
- Medium Structural Grade
- Heavy Structural Grade
- Extra Heavy Structural Grade

The structural performance of each grade is detailed in Section P4.00 of this specification.

The following list gives some guidance as to the working areas where the various structural grades may be used:

- Light: General office accommodation without heavy equipment.
- Medium: General office accommodation where it is expected that heavy office equipment will be in use. Data preparation areas. Educational accommodation. Public areas.
- Heavy: Computer rooms, public areas, Data Centres, control rooms.
- Extra Heavy: Computer rooms with heavy equipment, Data Centres and other special applications.

P2.03

Constituent materials

The properties of constituent materials will be assumed to be known and verified in accordance with relevant standards and official codes in this field. Any materials not so covered shall be fully described and will be assessed by the Authority.

The floor system shall not contain materials which by direct contact or otherwise can be detrimental to the comfort and safety of the users or which may emit abnormally toxic combustion products.

There shall be no detrimental reactions from the contact between various parts of the floor system or between the floor system and its fixings or adjoining building materials.

Where possible materials shall be from a sustainable source (such as FSC).

All materials, products and processes used in the design, manufacture and installation of platform floors shall satisfy the requirements of the Health and Safety Executive (COSHH) Regulations.

P2.04

Fixings and fastenings

The floor system fixings and fastenings shall be designed to prevent vibration, rocking, rattles, squeaks and other noises. It shall be possible to remedy such defects which might develop in service. The floor system shall be sturdy, rigid and firm.

P2.00 | Description

P2.05

Accessories

Any component in the floor should be of equal or greater strength than the main floor plate. This is rolling and static loads can be placed on these items with the same confidence as the main floor.

Bar type air grilles shall comply with the performance and test requirements as stated in Appendix A.

P2.06

Floor coverings - general

Where floor coverings are supplied as an integral part of the system, they shall comply with the requirements of Section P8.00 of this specification. This requirement applies to floor coverings which form part of the floor suppliers specification and to floor coverings which are specified by others for fixing by the floor supplier.

Where the floor system is supplied without floor coverings, the supplier shall state any known limitations in respect of the application of floor coverings and their associated fixing agents.

P2.07

Design and manufacture

The component parts of the floor system are to be designed and manufactured in accordance with current good practice. Where materials are used which may deteriorate if subject to hygrothermal changes, they are to be used and stored in reasonably controlled environmental conditions and allowed to reach equilibrium before being subject to manufacturing processes.

P3.00 | Dimensional Requirements

P3.01

Size and dimensional framework

The supplier shall offer platform floor systems capable of normally being located, fixed and jointed within the discipline of a dimensional framework based on BS ISO 21723:2019 (or BS6750:1986 - Modular Co-ordination in Building, or the latest version if the one stated is superseded). In addition, the systems offered shall be capable of modification to meet the requirements of non-modular coordinated buildings such as in the case of refurbishment of existing buildings.

P3.02

Panel location

Each panel shall be located on its supporting pedestals by means of a positive location method.

This requirement shall not apply to fixed panels in partial access systems.

P3.03

Gaps between panels

The maximum gap between panels when located in their respective positions shall not exceed 1mm.

P3.04

Damage to services

The system shall not incorporate components with sharp edges or projections which could damage cables or services during installation, operation or maintenance of cables or services within the void.

P3.00 | Dimensional Requirements

P3.05

Shape: grid: dimension: weight

a. Full Access Floor

The first preference coordinating size of the panels shall be 600 mm x 600 mm. Other panel sizes e.g. 500mm x 500mm or 750mm x 750mm may be acceptable. All panels, with the exception of cut panels, are to be removable and fully transferable in both position and direction.

The weight of each panel shall not exceed 20 kg In accordance with the HSE (Health & Safety executive) Manual handling at work, panels above 20kg will require a two person lift.

The first preference dimensional grid of the supporting pedestals shall be of a coordinating size of 600 mm x 600 mm. A grid to suit other panel sizes would be acceptable. Additional pedestals adjacent to the perimeter around columns and under heavy loads etc. may be required and installed, providing they are acceptable to the Authority and that they do not interfere with any services installation.

The height of the finished platform floor level will be as stated in the particular contract documents.

The supplier shall state any limitation on the maximum and minimum height for his particular system and also if any cross bracings, stringers or additional pedestal fixings are required above a particular height.

The system shall be fully adjustable to cater for tolerances likely to be encountered in the level of the sub floor. Details of the sub floor including levels will be as detailed in the project tender documents. The supplier shall state limitations on adjustability.

b. Partial Access Floor

The fixed panels in a partial access floor system may be of any shape, size or weight that is considered fit for the particular application.

The preferred maximum size of the removable panels is 600 mm x 600 mm and the weight shall not exceed 20 kg In accordance with the HSE (Health & Safety executive) Manual handling at work, panels above 20kg will require a two person lift.

The first preference dimensional grid of the supporting pedestals shall be of a coordinating size of 600 mm x 600 mm.

Additional supplementary pedestals adjacent to the perimeter, around columns and under heavy loads etc., may be required and installed providing they are acceptable to the Authority and that they do not interfere with any services installation.

The height of the finished platform floor level will be as stated in the particular contract documents.

The supplier shall state any limitation on the maximum and minimum height for his particular system and also if any cross bracings, stringers or additional pedestal fixings are required above a particular height.

The system shall be fully adjustable to cater for tolerances likely to be encountered in the level of the sub floor. Details of the sub floor including levels will be as detailed in the particular contract documents. The supplier shall state limitations on adjustability.

P3.06

Fit

The system shall not rely on perimeter walls, columns etc., for lateral stability. It shall provide a close fit to all such interfaces whilst allowing for possible building movement and hygrothermal movement in the floor system but without any detrimental effect on the floor performance.

At perimeters and around columns etc., the maximum allowable gap shall be 15mm with edge panels being positively located to prevent lateral movement of the floor assembly.

Special consideration shall be given to the panel support arrangements at threshold interfaces which shall not create a hazard to pedestrians.

P3.00 | Dimensional Requirements

P3.07

Overall levels

Before the application of any load, the platform floor surface shall be level to within:

- a. ± 1.50 mm over any 5 metre square and
- b. ± 6.00 mm over any size of basic space.

The system shall be capable of adjustment to meet this requirement when the system is installed on a structural sub floor constructed to normal tolerances in accordance with good building practice.

P3.08

Panel levels

The difference in height between adjacent panels without floor finish, panels with a hard surface type floor finish and panels with lipped edges shall not exceed 0.75mm before the application of any load and shall not exceed 3.25mm between the edge of any panel being subjected to any of the static loadings specified in Section P4.00 and any adjacent unloaded panel.

P3.09

Panel flatness

The concavity or convexity of any panel under no load conditions shall not exceed 0.75 mm when measured horizontally parallel to any edge or diagonally across a 600 mm module. T1.00
T2.00

The deviation due to twisting under no load conditions of any corner in relation to the other three shall not exceed 1.00 mm over a 600 mm module. The flatness shall be maintained when the panel is subjected to the hygrothermal conditions stated in Section P5.00 and also after the removal of any specified concentrated or distributed loads. T22.00
T23.00
T24.00

P3.10

Panel squareness

The panel deviation from square shall not exceed 0.06% of the shorter diagonal length when measured to the nearest 0.5 mm. T3.00
T25.00

P3.11

Panel dimensions

The deviation from the work size of the panel shall not exceed ± 0.5 mm.

Note: Appropriate work size shall be chosen to suit the production process. e.g. 599.5 ± 0.5 mm giving limits of size of 599mm and 600mm

P3.12

Panel edge strip

Where panel edge strips are used, these shall be firmly fixed to the panel edges and shall not peel away, become detached or break when the panel is in use or when being removed or replaced in the manner proposed by the supplier. T4.00
T26.00

When subjected to the test detailed in Section T4.00 panel edging shall resist a pull off strength of 5N for 5 minutes without movement.

There shall be no tendency for the edge stripping to change in dimension during the stated service life.

The dimensional tolerances stated for panels shall apply with edge stripping in position.

P3.13

Panel interchangeability, installation and removal

The previous clauses in Section P3.00 do not remove the supplier's responsibility to provide a system where removable panels (with the exception of cut edge panels) are totally interchangeable and replaceable in any of four directions at 90 degree increments.

The removable panels shall be of such dimensions that they may be removed and replaced without damage and without the use of undue force by the lifting devices provided by the supplier.

Where panels are not capable of being lifted from one side without jamming, the lifting devices provided by the supplier shall be marked with the instruction "LIFT PANEL VERTICALLY".

P3.00 | Dimensional Requirements

P3.14

Air leakage rate

T6.00
T28.00

Where the under-floor space is designated in the project tender documents to be used as an air plenum, this should comply with the maximum air leakage rate between the joints in the panels and at the perimeter and maximum design pressure. The AFA would recommend working to the acceptable raised access floor leakage criterion of 1 l/(s.m2)@50 Pa as published by BSRIA in document BG/2016 Floor Plenum Airtightness Guidance and Testing Methodology. The supplier shall quote in their tender offer the air leakage rate for their system at this specified design pressure.

P4.00 | Structural Requirements

P4.01

Strength: grades

The complete floor system shall comply with one of the following working strength grade requirements:

Grade	Static Loadings	
	Concentrated Load	Uniformly Distributed Load
Light	Not less than 2.7 kN over 300mm sq. and Not less than 1.5 kN over 25mm sq.	Not less than 6.7 kN/m2
Medium	Not less than 4.5 kN over 300mm sq. and Not less than 3.0 kN over 25mm sq.	Not less than 8.0 kN/m2
Heavy	Not less than 4.5kN over 25mm sq.	Not less than 12.0kN/m2
Extra Heavy	Not less than 4.5kN over 25mm sq.	Not less than 12.0kN/m2
	This grade is also required to sustain a total load of 11kN applied equally on four points, each point 25mm sq. on a 200mm x 200mm square configuration at any point on the system	

P4.02

Static loading and deflection

T7.00
T8.00
T9.00
T10.00
T29.00
T30.00
T31.00
T8a.00

The system when in use or when subjected to the applicable tests shall not deflect or deviate more than 1/250th of the shortest *span or 2.5mm, whichever is the least, upwards or downwards from the unloaded plane when subjected to the particular static loadings quoted in the table to clause P4.01 for a period of 24 hours.

Any deflection or deviation shall be stable within that 24 hours. Stability is deemed to be a maximum of 0.02mm difference in deflection or deviation between 23 and 24 hours after application of the load.

The residual deflection in the system shall not exceed 0.5 mm when measured two hours after the removal of the load which has been applied for 24 hours.

The system shall carry any of the particular concentrated loads at any position e.g. around the perimeter, centre or centre of edge of any full panel, cut panel, access panel, perforated panel, panels with grilles, panels with electrical outlet boxes, etc., or at any point which could be considered a point of weakness.

The permanent indentation of the panels without floor finish shall not exceed 0.15 mm after the removal of any of the foregoing loads which have been applied for 24 hours.

A time of 2 hours may be allowed for the recovery of the materials.

** Note: For the purpose of this clause, the span shall be taken as the centre to centre dimension of the declared pedestal grid (600mm x 600mm).*

P4.00 | Structural Requirements

P4.03

Safety factor

T11.00

The system shall sustain THREE times the particular static loadings for 5 minutes without collapse with the exception of the 11 kN four-point static load required for the EXTRA HEAVY grade which shall be TWO times for 5 minutes without collapse. The system shall be capable of withstanding this load at any of the positions which has been subjected to the particular static load test.

T39.00

P4.04

Dynamic loading

T12.00

The system shall be subjected to:

T13.00

a) The soft body test T12.00 and T32.00 and

T32.00

b) The hard body test T13.00 and T33.00. These tests shall not cause any part of the system to collapse.

T33.00

P4.05

Pedestrian dynamic loading

T14.00

The system shall not excessively "bounce" or move when subjected to pedestrian and light wheeled traffic.

T34.00

The system is required to be subjected to the pedestrian dynamic load tests detailed in the Test Sections T14.00 and T34.00 for 250,000 cycles without developing any appreciable movement, wear, de-lamination, cracking or other deterioration. The allowable movement is defined by:

- a. Horizontal movement shall not exceed 1.5 mm and shall not increase by more than 0.5 mm over the period of the test.
- b. Vertical deflection shall not exceed 1 mm and shall not increase by more than 0.33 mm over the period of the test.

After the completion of the pedestrian test on a full access system, the panel under test shall be subjected to the particular point load test detailed in the Test Section T8.00 to the centre of the panel. The deflections produced shall be within the requirements detailed in Clause P4.02.

After completion of the pedestrian test on the 2400 x 2400 mm area of partial access flooring, the positions under test shall be subjected to the particular point load test detailed in the Test Section T30.00. The deflections produced shall be within the requirements detailed in Clause P4.02.

The tests shall be carried out on a sample of the maximum height of the system offered for assessment. If the height of the system to be approved is greater than 300 mm, the tests may be carried out on a sample 300 mm high overall.

P4.06

Pedestal structure and fixing

T42.00

Pedestals shall be structurally sound and remain rigid and firmly secured to the sub floor throughout their life expectancy as specified by the manufacturer, see P11.01.

Pedestals for Medium, Heavy and Extra Heavy grade systems shall have a base area of not less than 10,000mm². Pedestals for Light grade systems shall have a base area of not less than 8,000mm². The bases shall be designed to evenly transmit the particular static loads over the full area to the sub floor. Pedestals are to be fixed to the sub floor by mechanical fixings in addition to any adhesives, unless the supplier can prove that, without such mechanical fixings, the pedestals will not become detached from the particular sub floor, when subjected to the Site Quality Control Pedestal Fixing Test detailed in Clause T42.00. When necessary, this test shall be carried out for each contract before the general installation of the floor system is commenced.

In addition to the foregoing test, the supplier shall arrange to have site quality control tests, detailed in test method T42.00, carried out on each site as the installation proceeds. Pedestals shall be selected at random, at the rate of 0.5% (or mutually agreed reasonable representation).

The selection of test specimens and test results shall be to the satisfaction of the Authority. All pedestals are required to be fixed plumb. The supplier is required to state the proposed method of fixing and shall quote the sub floor finish required for the fixing to be effective.

The supplier shall provide a copy of the relevant and approved installation instructions to the Authority.

If a pedestal fails the test, a second test should be carried out within a 3m square area around the failed pedestal. Pedestals which detach due to subfloor/slab failure will require mechanical fixing.

P4.00 | Structural Requirements

P4.07

Pedestal stability and strength

T15.00

Pedestals for full access systems and pedestals for partial access systems which are not permanently fixed to the underside of panels, when free standing and fixed to a suitable rigid substrate by means of the method proposed by the supplier shall not be permanently deformed by more than 1 mm per 100 mm in height or 1 mm if the pedestal is less than 100 mm high when subjected to a steady horizontal moment of 90 Nm within the range of applied loads from 9 kg minimum for pedestal heights of 1 metre and above and 50 kg maximum for pedestal heights below 185mm, applied to the uppermost part for five minutes. Pedestals shall not become detached from the rigid substrate due to failure of the fixing method whilst being subjected to the foregoing load.

Pedestals are required to sustain the following vertical loads over an area of 50 mm x 50 mm for a period of five minutes without collapse:

- a. 4 times the particular static concentrated load applied through the panels at the centre of the head.
- and
- b. 3 times the particular static concentrated load applied through a panel over one quadrant of the head.

Note: The requirement b. is applicable to Full Access systems and pedestals supporting access panels in Partial Access systems only.

Grade	Table of Vertical Pedestal Loads	
	Load applied over the area of head	Load applied over one quadrant of the head
Light	10.8 kN	8.1 kN
Medium	18 kN	9 kN
Heavy	18 kN	13.5 kN
Extra Heavy	18 kN	13.5 kN

T16.00
T36.00

Free movement in an unloaded pedestal at the maximum and minimum adjustment positions shall not exceed 1 mm per 100 mm height. The free movement shall be induced by the application of a horizontal force of 5N.

T5.00
T27.00

The adjusting device on the pedestal shall be positively locked and shall not become loose due to vibration or other causes during the life of the system. It shall be possible to release the locking by means of a tool should readjustment become necessary.

P4.00 | Structural Requirements

P4.08

Perimeter details

The installation at the perimeters of the system and around columns etc., shall comply with all the relevant requirements of this specification.

P4.09

Bridging structures

Where a supplementary support structure is required to accommodate variation more than construction tolerances e.g. to bridge service ducts etc., it shall comply with all the relevant requirements of this specification.

P4.10

Safety of the system when panels are removed

The supplier shall state the maximum number and positions of panels that may be temporarily removed at any one-time during servicing without endangering the safety of the floor system.

P4.11

Weight of the system

The supplier is required to state the installed weight per m² of each system included in the Schedule of performance offer at Appendix B.

P4.12

Identification of structural grades

The structural grade of the system shall be identified by means of a colour code marking as follows:

- LIGHT GRADE - GREEN
- MEDIUM GRADE - YELLOW
- HEAVY GRADE - RED
- EXTRA HEAVY GRADE - BLUE

The marking shall be indelibly applied to each panel, pedestal and stringer (if applicable) and shall be at least 10 mm sq.

P4.13

Installation of heavy equipment

It is regarded as good practice to use spreader boards to move heavy equipment, in order to enable even distribution of loads and prevent damage to the floor panel surface.

P5.00 | Hygrothermal Requirements

P5.01

Moisture and thermal movement

The platform floor system, including the pedestals, panels, floor coverings and all fixings shall be capable of complying with the performance requirements stated in this document without any de-lamination or other forms of deterioration when subjected to the following hygrothermal conditions:

- a. Temperature 5 °C. Relative humidity 90% on both sides of the floor panels. This condition could be expected in an unheated building in winter.
- b. Temperature 5 °C and 95% RH in the floor void side of the panels. Temperature 25 °C and 25% RH on the room side of the panels. These conditions could apply to floors over GF slab in winter.

P5.00 | Hygrothermal Requirements

- c. Temperature 8 °C and 95% RH in the floor void side of the panels. Temperature 23 °C and 45% RH on the room side of the panels. These conditions could apply where the void is used as a plenum chamber for supply air with the A/C system in the cooling mode.
- d. Temperature 30 °C and 30% RH in the floor void side of the panels. Temperature 19 °C and 60% RH on the room side of the panels. These conditions could apply where the void is used as a plenum for supply air with the A/C system in the heating mode.

The supplier is required to state the extent of movement that will occur in the platform floor system when stabilisation has been reached under the conditions given in (a), (b), (c) and (d). They shall also state what effects such movement will have on the system.

The above environmental range applies to indoor conditions in the UK. More onerous conditions may be encountered in the vicinity of heating and cooking appliances and also during transportation, site storage or installation where rapid changes from 0 - 30 °C have been known to coincide with humidity levels of 25 to 95%. Conditions which may be encountered in overseas territories are also likely to be more onerous. Any limitations of use caused by the effects of possible exposure to extreme conditions shall be stated explicitly by the supplier.

P5.02

Deemed to satisfy the authority

The system shall be deemed to satisfy the Authority in respect of the hygrothermal requirements if sample panels from a FULL access system or sample removable panels from a PARTIAL access system:

- a. Do not change in concavity, convexity and twist by more than the limits stated in Clause P3.09.
- b. The materials or components do not de-laminate.
- c. Comply with the requirements stated in Clause P4.01 and P4.02 for the concentrated load over 25mm x 25mm after such samples have been subjected to the temperature or humidity conditions stated in the Method of Test Sections T17.03 and T18.03.

The point load tests shall be commenced 24 hours ± 1 hour after the samples have been removed from the conditioning apparatus.

Sample fixed panels of PARTIAL access systems which are normally joined to their adjacent panels by means of tongue and grooves and the like and which are fixed to the supporting pedestals shall be subjected to the temperature and humidity conditions stated in the Method of Test Sections T37.03 and T38.03 after which they shall be measured and examined as 'a' and 'b' above. These results shall be reported by the test authority but will be considered as indicative only and will not represent a pass or fail criteria.

However, the Authority may not accept the system if, in their opinion, the results are not considered to be satisfactory. The opinion of the test authority may also be taken into account.

P5.03

Sealing edges of cut panels

Where panels consist of a substrate which will absorb moisture and which are nominally sealed against the ingress of moisture on all faces, all cut edges shall be suitably sealed against the ingress of moisture to prevent any deterioration of dimensional and structural performance.

P6.00 | Fire and Safety Requirements

P6.01

General

The system shall meet all the requirements detailed in Clauses P6.02 to P6.08 inclusive and should also meet the relevant fire requirements of BS9999:2017 (or latest version if superseded): British Standard Code of Practice for Office Buildings.

When the system is to be installed within a building for the purpose of housing electronic data processing equipment, it shall comply with the fire requirements of BS6266: 2011: British Standard Code of Practice for fire protection for electronic data processing installations. For the purposes of this Performance Specification the manufacturer shall state, whether the system meets the fire requirements of BS 6266: 2011 and clearly define any limitations.

The results of the indicative Test T20a .00 for thermal properties shall also be stated, as required by clause P6.08.

P6.02

Spread of flame

T19.00

T40.00

Within the cavity, the system shall achieve:

- a. "Class 1" surface classification when tested in accordance with BS476 : Part 7 and
- b. An Index of Performance (1) not exceeding 12 and a Sub Index (i) not exceeding 6 when tested in accordance with BS476: Part 6.

P6.03

Panel cladding

T19.00

T20.00

Panels which are constructed using combustible material shall be completely and securely clad on the underside in non-combustible material which shall have a melting point of not less than 600 °C. This cladding shall be securely fixed to the panel in order to ensure that flame or radiant heat do not come in contact with the combustible material when subjected to the spread of flame, index of performance, and fire resistance tests.

T40.00

T41.00

P6.04

Structural materials

The supporting structure, i.e.. pedestals, stringers and other supports shall be non-combustible and shall be constructed from materials having a melting point of not less than 550 °C.

P6.05

Compliance with tests

The fire resistance of the system shall be assessed by means of the test detailed in the Test Section T20.00 and T41.00.

The section of the floor system under test shall carry the particular specified distributed load as detailed in the method of test, when subject to the heat and flame from a 1070g ± 30g standard fire crib which shall be mounted as near as possible to a pedestal. The clear void height below the floor panels shall be 300mm.

The allowable deviation anywhere in the system during and after the test shall not exceed 10mm.

The supporting structure shall not become unstable and shall show no signs of deformation or failure at the end of the test.

There shall be no flame penetration through gaps in the panels although a certain amount of smoke is allowable, but during the test, the system shall not emit abnormal toxic products.

In special circumstances, systems may be required to have a fire rating other than the foregoing. Any such requirements would be detailed in the particular contract documents.

P6.06

Cavity barriers

The system shall incorporate purpose made cavity barriers when required, which shall be designed and installed in accordance with the latest relevant building legislation.

P6.00 | Fire and Safety Requirements

P6.07

Perimeter and bridging structure details

The installation at the perimeter of the system, around columns and any bridging structures, including cut panels and perimeter supports shall comply with the relevant fire and safety requirements stated in this section.

P6.08

Thermal properties

T20a.00

T41a.00

The supplier is required to provide an assessment of the thermal properties of the system by means of the test detailed in the test section T20a.00 (full access systems) and T41a.00 (partial access systems).

A sample specimen shall be subjected to the heat source from a 1070g ± 30g standard fire crib and the top surface temperature shall be recorded to provide the mean face temperature and the maximum face temperature above its initial value.

The test results will give an indication of the thermal properties of the installed system when considered in conjunction with the applied floor finishes and other environmental factors associated with the particular installation.

Requirements for thermal properties, if any, will be detailed in the particular contract documents based on the performance criteria of BS 476: Part 20: 1987: Section 10.4.

P7.00 | Transmission of Sound

The supplier shall, on request, provide the Authority with a report from a recognised independent sound test laboratory which will give an indication of the transmission of airborne sound performance of the system.

The system should be tested in a laboratory to obtain measurements of the Floor Normalised Level Difference following the general guidance of BS EN ISO 10848-2: 2017 which prescribes a method of test for suspended ceilings but may, for the purpose, be inverted and applied to a platform floor system.

A single figure rating of the sound insulation performance known as the Weighted Floor Normalisation Level Difference (D_{nf,w}) may be derived from the measurements following the procedure prescribed in BS EN ISO 717-1: 2013, BS EN ISO 10140-2: 2010, BS EN ISO 10140-4: 2010, BS EN ISO 10140-1: 2016, BS EN ISO 10140-5: 2010 + A1: 2014, BS EN ISO 10140-3: 2010 + A1: 2015

The method of measurement shall be as prescribed in BS2750: 1980.

P8.00 | Floor Coverings

P8.01

General

The supplier shall provide the type of floor coverings as detailed at Appendix B or other particular contract documents. Where floor coverings are specified, they shall be provided as an integral part of the supplier's floor system. The floor systems offered shall be capable of incorporating integrated floor coverings to the specifications listed in Clauses P8.02 and P8.03 of this specification and the project particulars subject to the recommendations for use and application made by the floor covering supplier.

P8.00 | Floor Coverings

P8.02

Coverings recommended for computer suites with full access ventilated floors

- a. High pressure laminate (HPL) of Class BS EN 438-1: 2016 and BS EN 438-2: 2016 + A1: 2018.
- b. Anti-static grade sheet PVC to BS EN ISO 10581:2020 or equivalent.
- c. Anti-static grade fibre bonded carpet.

Note: it is recommended that this covering is only used when a conditioned air supply is through floor grilles and extracted at ceiling level or when a conditioned air supply is from the ceiling level and extracted through floor grilles or perforated floor panels.

P8.03

Coverings recommended for general accommodation areas other than computer suites (Section removed)

P8.04

Not used

P8.05

Fitting and installation

The bonding of floor coverings to individual panels shall comply with the following requirements:

- a. Adhesives shall be as recommended by the floor covering manufacturer for the particular covering material and the panel substrate and shall be used in accordance with the adhesive manufacturers' instructions.
- b. The covering shall be fully bonded to a smooth and level panel substrate covering the entire top surface area of the panel. Joints in the material will not be acceptable. The bond shall remain effective for the design life of the covering material.
- c. Where the panels are to be lifted by means of a lifting device applying force to the covering, the adhesion between the covering and the panel shall be adequate for panel of up to 20 kg to be lifted without causing any failure of the bond. The lifting device shall not cause damage to the covering material when used in accordance with the manufacturer's instructions.
- d. Not Used.

Where required, the floor covering edges shall be protected by means of suitable edge strips applied to each panel on full access systems and to each access panel and around each orifice on partial access systems.

See Clause P3.12 for the performance requirements of panel edge strips.

P8.06

Cleaning

The floor finish shall be capable of being cleaned using routine cleaning methods. The supplier shall state the floor covering manufacturer's recommendations for cleaning the floor covering which should be compatible with the adhesives and the panel substrates used.

9.00 | Electrical Requirements

P9.01

Electrostatic properties

Where platform floors are to be used in accommodation housing computer equipment, the resistance between the surface of the floor covering and the main building earth continuity conductor shall be between 10^5 and 2×10^{10} ohms when measured in accordance with the Test Method detailed in Clause T43.00 after the installation is completed and the relative humidity (RH) stabilised at $50\% \pm 10\%$ for at least 48 hours.

The supplier shall arrange for the test to be carried out at each particular site where the property is a requirement.

P9.02

Equipotential bonding

All substantial metallic components of the floor system shall be capable of being electrically bonded.

The supplier shall detail methods of such bonding.

P9.03

Earthing and bonding

Where required by the Regulations for Electrical Installations published by the Institution of Electrical Engineers (Latest Edition), electrically conductive components of platform floor systems shall be connected to earth in a manner which satisfies those regulations. In general, this can usually be achieved by the means described in a. to d. However, in cases of doubt a suitably qualified electrical engineer should be consulted.

- a. All conductive components forming the floor system shall be connected to the earth bar of the power distribution board serving the area. The connections shall be by means of conductors having substantial and reliable metal to metal contacts which are of negligible impedance and capable of carrying any earth fault current that can arise from any electric cables and equipment associated with the platform floor system, cables that are routed below the floors or cables to portable electrical power tools etc., that are likely to be used below the floor; these earthing connections shall also be capable of carrying the earth fault current for the duration of the disconnection time of the particular circuit protection device for any of the aforementioned faulty circuits.
- b. In practice, the requirements of clause 'a' can be satisfied using the conductive components of the platform floor systems themselves without the use of additional earthing or protective conductors providing those components and the joints between them comply with the requirements of 'a'. All metal to metal connections shall be designed so that their electrical efficiency cannot be impaired by incorrect installation. The exposed conductive parts of all the electrical equipment and other fittings, whether carried by the platform floor system or independently mounted, shall be bonded to the platform floor system either by means of their metallic fixings or by means of separate bonding conductors.
- c. The exposed conductive parts of cable trunking or conduit incorporated as an integral part of a platform floor system shall be earthed by means of a circuit protective conductor.
- d. After installation, platform floor systems shall be electrically tested in accordance with the Test Method described in Test Clause T44.00. When the resistance measured is added to the resistance of the other parts of the path forming the earth fault loop, the total should not exceed that required to operate the particular earth fault protection device within the disconnection time required by the Latest Edition.

10.00 | Side Effects

P10.01

Fungi, moulds and insects

All materials used in the platform floor system shall be resistant to the growth of fungi and micro-organisms and to attack by insects.

The supplier shall state what preventative measures will be taken to ensure that all materials in the offered system have the required resistance to such attack.

The resistance of organic materials to fungi, mould or mildew shall be tested in accordance with BS 1982-0: 1990, BS 1982-1: 1990, BS 1982-2: 1990, BS 1982-3: 1990 'Methods of test for fungal resistance of manufactured building materials made of or containing materials of organic origin'.

P10.02

Toxicity

The platform floor system shall not contain any toxic materials which by physical contact or by inhalation of gases from such materials could prove harmful to the occupants of the building

P10.03

Odour

The materials used in the construction of the platform floor system shall not give off any odours which could be unpleasant to the occupants of the building.

P10.04

Vermin

The platform floor system shall be designed, constructed and installed to resist infestation by vermin.

P10.05

Creation of dust and harmful contaminants

The platform floor system and the floor panels in particular, shall not create dust or contaminants which are likely to be harmful to personnel or equipment. This is particularly important where the underfloor void is to be used as a plenum for air conditioning.

11.00 | Durability

P11.01

Life of components

In the platform floor system, it is desirable that the supporting components should have a minimum life of 50 years and that the floor panels should have a minimum life of 25 years (excluding the floor covering).

The supplier shall state the minimum design life during which the floor system is expected to meet the performance requirements detailed in this document in respect of:

- a. The complete system.
- b. The supporting system.
- c. The floor panels.
- d. The floor covering (when applicable).
- e. Any other replaceable components.

The supplier is also required to state:

- a. The minimum maintenance free period of life of the whole system.
- b. The recommended methods and period of maintenance for the system.
- c. The minimum maintenance free period of life of any replaceable parts where this is different from that of the whole system.
- d. The minimum period that replaceable components will be available.

P11.02

Protective Finishes

All parts of the platform floor system shall be installed free of rust, corrosion, rot or any form of deterioration and shall be suitably finished so as to prevent such deterioration in normal use in the environment defined in Clause P5.01.

The supplier shall state the type and standard of the protective finishes they intend to use.

12.00 | Transportation & Storage on Site

The supplier shall take full responsibility for the loading and transportation of their components to site, and also, in circumstances where there is no Main Contractor, for the unloading and storage on site.

The supplier shall also agree the site storage conditions with any Main Contractor appointed thus ensuring that the floor system components will not be stored in moist or adverse conditions before installation commences. Platform floor system components shall not be stacked in a manner which would cause excessive loads to be placed on building sub-floors.

13.00 | Supply & Installation

P13.01

General

The supplier shall carry out all operations necessary to ensure that the installed platform floor system maintains the performance as set out in this document and as specified in the particular contract documents.

P13.02

Working time

The supplier shall organise the delivery, site storage and installation of the floor system as required by this contract. They shall notify the authority of the period of time that will be required to erect the system and also the period of time that will be required before any load may be put on to the system due to the setting time of pedestal adhesives etc.

P13.03

Sealing

Where specified the supplier shall apply a sealant to all concrete and brickwork etc., within the floor void to prevent dusting throughout the life of the installation. The sealant shall be compatible with any materials used to fix or pack the pedestals. If compatibility is not possible, then the surface of the sub floor may be prepared local to the pedestal bases.

P13.04

Cavity barriers, fire barriers & fire stopping

Before erection of the platform floor system, all openings into the floor void shall be fire stopped to the satisfaction of the Authority.

Cavity Barriers under the raised access floor system should be installed in accordance with the manufacturer's installation instructions.

In line with Approved Document B – The installation of Fire Barriers, Fire stopping products & all holes for services through any cavity barrier shall be fire stopped and should be carried out by a competent person and to the satisfaction of the local authority.

P13.05

Cleaning the void

The supplier shall ensure that the void below the floor is clean and dust free. This is particularly important where the void is to be used as a plenum for air conditioning.

P13.06

Protection of completed work

The supplier shall advise the authority on protection of completed work and carry out such precautions where provided for in particular conditions of contract. Where a main contractor is appointed the supplier shall advise his site representative of the maximum working loadings for the particular system.

The supplier shall demonstrate the method of lifting panels to any other sub-contractors or person in authority who needs to know.

14.00 | Test Evidence

All systems offered to the Authority shall comply in all respects with this Performance Specification.

Each system offered shall be tested in accordance with the test methods detailed in Section 'T' by an approved independent test laboratory and the subsequent test reports which shall be submitted to the Authority, shall confirm that the system will comply with the relevant clauses of this Performance Specification.

Each test report shall include dimensional and material details together with a full product specification and related drawings which shall be validated by the test authority.

Where specified by the Authority provide the information, as detailed in schedule of Performance shown in Appendix B, with each offer.

CONTENTS | Section T

METHODS OF TEST FOR TYPE APPROVAL & SITE QUALITY CONTROL

T0.00	General	28
-------	---------	----

FULL ACCESS FLOOR SYSTEMS

T1.00	Concavity and Convexity	28
T2.00	Twist	29
T3.00	Panel Squareness	29
T4.00	Pull off Strength of Panel Edge Strip	30
T5.00	Test for Free Play in Pedestal	31
T6.00	Air Leakage Rate	32
T7.00	300mm square Loading Test	32
T8.00	25mm Square Loading test	34
T8A.00	25mm Square Point Loading Test on Perimeter Cut Panel Edge	35
T9.00	Four Point Loading Test	37
T10.00	Uniformly Distributed Load Test	38
T11.00	Safety Factor Load Tests	40
T12.00	Soft Body Impact Test	41
T13.00	Hard body Impact Test	42
T14.00	Pedestrian Dynamic Load Test	43
T15.00	Pedestal Strength - Horizontal Load	44
T16.00	Pedestal Strength - Vertical Load	45
T17.00	Effect of Temperature	47
T18.00	Effect of Humidity	47
T19.00	Determination of Surface Spread of Flame and Index of Performance (Fire)	48
T20.00	Small Scale Fire Test	49
T20a.00	Thermal Properties	50

PARTIAL ACCESS FLOOR SYSTEMS

T21.00	Test Specimens	55
T22.00	Concavity & Convexity: Removable Access Panels Only	56
T23.00	Panel Levels & Panel Flatness: Fixed Panels	57
T24.00	Twist: Removable Access Panels	58
T25.00	Panel Squareness: Removable Access Panels	59
T26.00	Pull off Strength of Edge Strip: If Applicable	59
T27.00	Test for Free Play in Pedestal	60
T28.00	Air Leakage Rate	61
T29.00	300mm Square Loading Test	62
T30.00	25mm Square Point Loading Test	63
T31.00	Uniformly Distributed Load Test	65
T32.00	Soft Body Impact Test	66
T33.00	Hard Body Impact Test	68
T34.00	Pedestrian Dynamic load Test	69
T35.00	Pedestal Strength - Horizontal Load	70
T36.00	Pedestal Strength - Vertical Load	71
T37.00	Effect of Temperature	72
T38.00	Effect of Humidity	73
T39.00	Safety Factor Load Tests	74
T40.00	Determination of Surface Spread of Flame and Index of Performance (Fire)	75
T41.00	Small Scale Fire Test	76
T41a.00	Thermal Properties	78

CONTENTS | Section T

METHODS OF TEST FOR TYPE APPROVAL & SITE QUALITY CONTROL

SITE QUALITY CONTROL TESTS

T42.00	Pedestal Structure & Fixing Test	28
T43.00	Electrical Resistance Test for Electrostatic Control	29
T44.00	Electrical Continuity Test	29

T0.00 | General

In order to confirm that the system offered will comply with the relevant clauses of the Performance Specification, the following tests shall be carried out in accordance with the test methods detailed, by an independent UKAS Accredited test laboratory. The subsequent test report shall contain the information detailed for each test and shall also include dimensional and material details together with a full product specification and related drawings which shall be validated by the test authority.

T0.01

Environmental conditions

The environmental conditions for all tests shall generally be within the range of $20^{\circ}\text{C} \pm 10^{\circ}\text{C}$ and $55\% \pm 20\% \text{RH}$. The test report shall state the average condition which has applied over the duration of each test.

T0.02

Summary of results

A summary of results which shall indicate a pass or failure for each test carried out shall be included in the test report.

A statement that the system tested DOES or DOES NOT comply with the relevant clauses of the Performance Specification shall also be included in the test report.

METHODS OF TEST FOR FULL ACCESS FLOOR SYSTEMS

T1.00 | Concavity & Convexity

T1.01

Test specimen

Five panels without floor covering selected at random from samples submitted.

P3.09

P5.02

T1.02

Mounting for test

Each of the five panels shall be mounted in turn ON SUITABLE APPARATUS PROVIDING LEVEL SUPPORT TO ALL 4 PANEL CORNERS.

T1.03

Method of test

The concavity or convexity shall be measured across the two diagonals and at four points equidistant across the panel parallel to two opposite edges. The measurements shall be determined using a bridge and dial gauge to an accuracy of 0.01 mm. See Figure 1.

T1.04

Test report

The test report shall contain the following information:

- The module size of the panel.
- The environmental conditions at the time of measurement.
- The maximum concavity or convexity of each panel.
- The specified limit of 0.75 mm max.

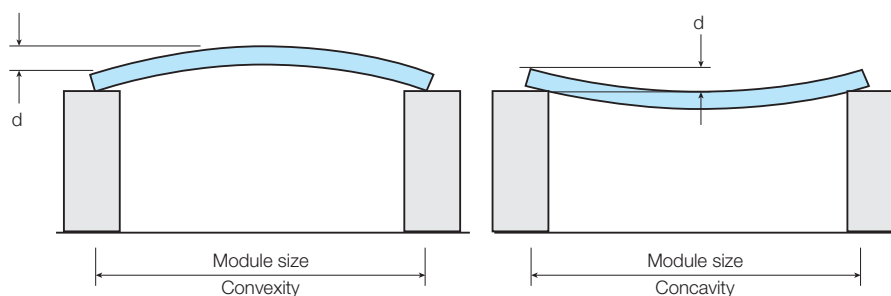

Figure 1

T2.00 | Twist

T2.01

Test specimen

The five panels used for Test T1.00.

P3.09

P5.02

T2.02

Mounting for test

The panels shall be tested on a plane reference surface.

T2.03

Method of test

The top surface of each panel shall be brought into contact with the plane reference surface or reference points on a plane so that three out of the four corners of the panel are in contact with the reference surface or points. The distance of the fourth corner from the reference surface or point shall be measured to an accuracy of 0.01 mm. See Figure 2.

T2.04

Test report

The test report shall contain the following information:

- a. Module size of the panels.
- b. The environmental conditions at the time of measurement.
- c. The maximum twist (d) Figure 2 of each panel.
- d. The specified limit of 1 mm max.

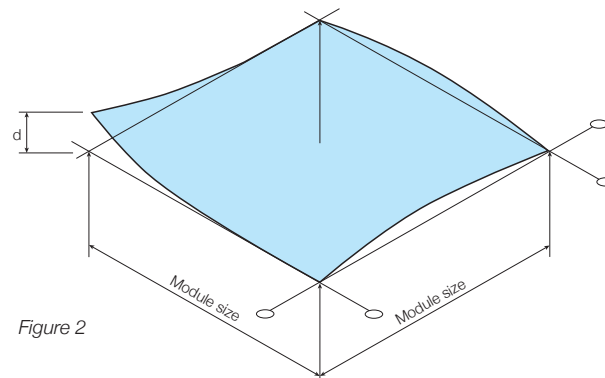

T3.00 | Panel Squareness

T3.01

Test specimen

The five panels used for Test T1.00.

P3.10

T3.02

Mounting for test

None required.

T3.03

Method of test

The two diagonals shall be measured to an accuracy of 0.5 mm. See Figure 3.

T3.00 | Panel Squareness

T3.04

Test Report

P3.10

The test report shall contain the following information:

- Module size of the panels.
- The environmental conditions at the time of measurement.
- The diagonal measurements of each panel.
- The difference between the two diagonal measurements of each panel.
- The difference expressed as a percentage of the shorter diagonal for each panel.
- The specified limit of 0.06% max.

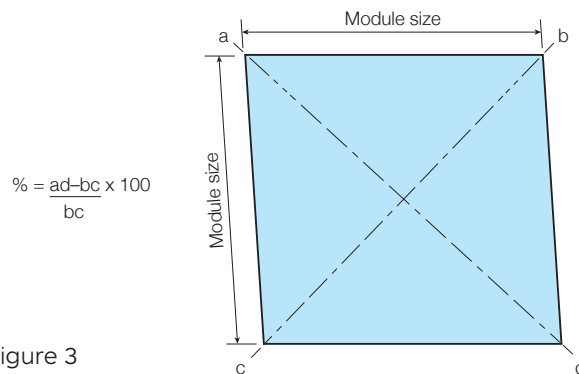

Figure 3

T4.00 | Pull-off Strength of Panel Edge Strip

T4.01

Test specimen

P3.12

One of the panels used in tests T1.00 to T3.00.

T4.02

Mounting for test

The panel shall be firmly mounted with the face vertical and each edge, in turn, horizontal.

T4.03

Method of test

The end of each edge strip shall be peeled off for a distance of 75mm with the panel mounted as above and the strip to be tested on the lower horizontal edge. A weight of 0.5 kg (giving a force of 5N) shall be attached to the strip and held for 5 minutes.

The three other edges shall be tested in a similar manner. See Figure 4.

T4.04

Test report

The test report shall include the following information:

- Description of the edge strip.
- Type of fixing.
- The environmental conditions at the time of test.
- Distance peeled after the application of force at each edge. Note: All results should be NIL.
- The specified limit - "No movement".

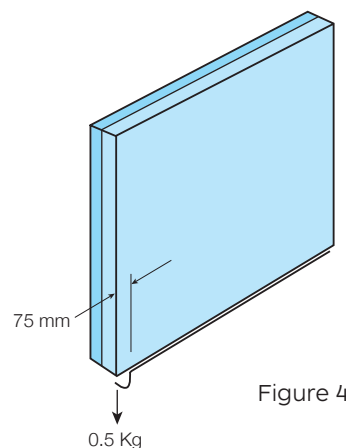

Figure 4

T5.00 | Test for Free Play in Pedestal

T5.01

Test specimen

P4.07

Two pedestals which shall be the maximum height of the type of system submitted.

T5.02

Mounting for test

The pedestals shall be firmly fixed to a horizontal surface.

T5.03

Method of test

The free play in the pedestal shall be measured in a manner similar to that shown in Figure 5.

A horizontal load of 5N shall be applied to the pedestal head, this load shall then be applied in the opposite direction and the total movement at the head, if any, shall be measured to an accuracy of 0.01 mm. See Figure 5.

T5.04

Test report

The test report shall include the following information:

- a. A description of the pedestal including details of any material used to restrict movement e.g. epoxy resin in threads or joints.
- b. Height of pedestal (h).
- c. Total movement.
- d. Total movement per 100mm height.
- e. The specified limit of 1 mm per 100 mm height.

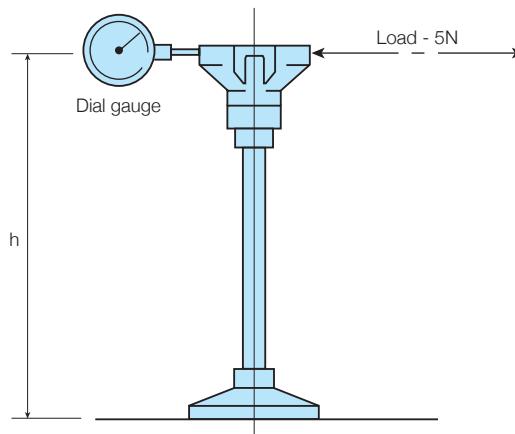

Figure 5

T6.00 | Air Leakage Rate

T6.01

Test specimen

P3.14

Four undamaged panels from previous tests and nine pedestals.

T6.02

Mounting for test

The four panels shall be set up on nine pedestals in a suitable airtight box as shown in Figure 6. The gap between the periphery of the panels and the box shall be sealed.

T6.03

Method of test

A fan shall be connected via a suitable air flow meter to the cavity formed by the floor specimen in the box. The pressure formed in the cavity shall be measured by means of a manometer and shall be adjusted to the required level. The rate of flow at the required pressure level shall be measured over a test period of at least 5 minutes or longer if necessary, to determine the volume flow of air to within 2%.

T6.04

Test report

The test report shall include the following information:

- a. A description of the joint between panels.
- b. The environmental conditions at the time of test.
- c. The air leakage rate measured and calculated as litres per minute per metre length of joint at the following mm wg pressures: 2.5, 5, 7.5, 10, 12.5, 15, 17.5, 20, 22.5 and 25.
- d. A statement that this test is indicative only.

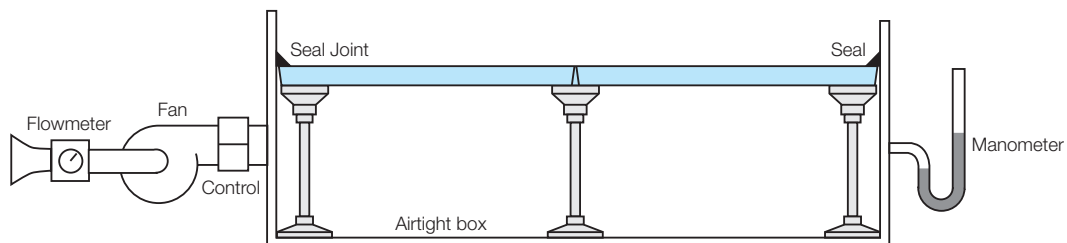

Figure 6

T7.00 | 300 mm Square Loading Test

(Applies to light & medium grades only)

T7.01

Test specimen

P4.01

Two panels with eight pedestals selected at random. The specimen shall be of the maximum height of the type of system submitted. P4.02

T7.02

Mounting for test

The pedestals shall be bonded on to a rigid substrate by means of the adhesive and any mechanical fixings submitted. The pedestals shall be adjusted to the maximum recommended height and each panel set up level on four pedestals. The test shall be commenced 48 hours \pm 5 hours after the adhesive, if any, was first applied.

T7.00 | 300 mm Square Loading Test

(Applies to light & medium grades only)

T7.03

Method of test

The indenter shall be a steel plate 300 mm square and not less than 10 mm thick with corners rounded to a radius of not more than 2 mm. It shall be weighed, and the force exerted by this weight shall be deducted from the applied load. The indenter shall be applied:

- a. To the centre of the first panel.
- b. To the centre of edge of the second panel such that one edge of the indenter is contiguous with the panel edge and the centre lines of indenter and panel are coincidental.
- c. To an adjacent centre of edge of the second panel such that one edge of the indenter is contiguous with this edge and the centre lines of indenter and panel are coincidental.

A bedding-in load consisting of the test load shall be applied and maintained for a period of 5 minutes via the indenter and then released. An unloaded period of 5 minutes \pm 1 minute shall elapse before the commencement of the actual test and the zero-load deflection reading is taken.

The particular static load specified in Clause P4.01 shall be applied and maintained for 24 hours at the centre of the indenter by means of suitable test apparatus similar to that shown in Figure 7.

The deflections produced by this load shall be measured to an accuracy of 0.01mm at:

- a. The centre of the first panel.
- b. The centre of each loaded edge of the second panel.
 - i. the instant the load is applied.
 - ii. 23 hours after the load was first applied.
 - iii. 24 hours after the load was first applied and before removal of the load.
 - iv. 2 hours after the load was removed.

Two hours after removal of the load, the top surface of the panels shall be examined, and any indentation caused by the loaded indenter shall be measured. The test specimen shall also be examined for any other permanent deformation caused by the test load.

T7.04

Test report

The test report shall include the following information:

- a. The structural grade of the system - Light or Medium and the test load.
- b. The average environmental conditions over the period of the test.
- c. Deflection in the system after 23 hours of loading.
- d. Deflection in the system after 24 hours of loading.
- e. Maximum permitted deflection: $1/250^{\text{th}}$ of the span or 2.5 mm whichever is the least.
- f. Difference between c and d (stability). Maximum 0.02 mm.
- g. Residual deflection 2 hours after load was removed. Maximum 0.5 mm.
- h. Permanent indentation of the top surface of panel. Maximum 0.15 mm.
- i. Any other permanent deformation in the system.

Note: Results c to i are required for each test position.

T8.00 | 25 mm Square Loading Test (Applies to all structural grades)

T8.01

Test specimens

Four panels with sixteen pedestals selected at random. The specimen shall be of the maximum height of the type of system submitted

P4.01

P4.02

T8.02

Mounting for test

The specimens shall be mounted as detailed for Test T7.00.

T8.03

Method of test

The indenter shall be a 25mm steel cube, the corners of which shall be rounded off to a radius of not more than 2mm.

The indenter shall be applied:

- a. To the centre of the first panel.
- b. To the centre of edge of the second panel.
- c. To an adjacent centre of edge of the second panel.
- d. To a point along a diagonal 70 mm beyond the edge of the pedestal head on the third panel and
- e. To any other point on the fourth panel which the testing authority may consider to be an area of weakness.

A bedding-in load, consisting of the test load shall be applied and maintained for a period of five minutes via the indenter and then released.

An unloaded period of 5 minutes \pm 1 minute shall elapse before the commencement of the actual test and the zero-deflection reading is taken.

The particular static load specified in Clause P4.01 shall be applied and maintained for 24 hours at the centre of the indenter by means of a suitable test apparatus similar to that shown in Figure 7.

The deflections produced by this load shall be measured at the centre of the indenter position on the panel to an accuracy of 0.01mm at:

- i. The instant the load is applied.
- ii. 23 hours after the load was first applied.
- iii. 24 hours after the load was first applied and before the removal of the load.
- iv. 2 hours after the load was removed.

Where deflection readings coincide with profile changes to the underside of the panel, then the average of two adjacent readings shall be recorded. These readings shall be taken directly below the indenter position, to record deflections each side of the profile change.

When the profile change to the panel soffit extends beyond the area of the indenter position then the deflection readings shall be obtained from the top surface of the panel immediately adjacent to the indenter.

The average of the two readings shall be recorded as the deflection produced, see Figure 6a.

Two hours after removal of the load, the top surface of the panels shall be examined, and any indentation caused by the loaded indenter shall be measured. The test specimen shall also be examined for any other permanent deformation caused by the test load.

T8.00 | 25 mm Square Loading Test (Applies to all structural grades)

T8.04

Test report

P4.01

P4.02

The test report shall include the following information:

- a. The structural grade of the system - Light, Medium, Heavy or Extra Heavy and the test load.
- b. The average environmental conditions over the period of the test.
- c. Maximum permitted deflection: 1 / 250th of the span or 2.5 mm whichever is the least.
- d. Deflection in the system after 23 hours of loading.
- e. Deflection in the system after 24 hours of loading.
- f. Difference between d and e (stability). Maximum 0.02 mm.
- g. Residual deflection 2 hours after load was removed. Maximum 0.5 mm.
- h. Permanent indentation of the top surface of panel. Maximum 0.15 mm.
- i. Any other permanent deformation in the system.

Note: Results d to i are required for each test position.

T8a.00 | 25mm Square Point Loading Test on Perimeter Cut Panel Edge

T8a.01

Test specimens

P4.01

P4.02

One panel cut to form two identical rectangular half panels, two pedestals and the requisite pedestals as normally used for a perimeter support detail together with any other components required for the perimeter support detail. All to be selected at random.

The specimen shall be of the maximum height of the type of system submitted.

T8a.02

Mounting for test

The pedestals shall be bonded to a rigid substrate by means of the adhesive and any mechanical fixings submitted.

The support of the panel cut edge shall be the method submitted by the manufacturer as being the normal detail adopted at a perimeter abutting vertical planes.

If the support method is of a type which is fixed to a solid vertical structure, then this structure shall be simulated by the test authority.

Pedestals and /or perimeter supports shall be adjusted to the maximum recommended height and the cut panel set up level.

The test shall be commenced 48 hours ± 5 hours after the adhesive, if any was first applied.

T8a.03

Method of test

The indenter shall be a 25 mm steel cube, the corners of which shall be rounded off to a radius of not more than 2 mm.

The indenter shall be applied to the cut edge of the panel such that one edge of the indenter is contiguous with the panel edge and positioned at either the centre, or at the centre position between any additional supplementary supports or at any point which the test authority may consider to be a point of weakness.

A bedding in load, consisting of the test load shall be applied and maintained through the indenter for a period of five minutes and then released. An unloaded period of 5 minutes ± 1 minute shall elapse before the commencement of the actual test and the zero deflection and deviation readings are taken.

T8a.00 | 25mm Square Point Loading Test on Perimeter Cut Panel Edge

The particular static load specified in Clause P4.01 shall be applied and maintained for a period of 24 hours at the centre of the indenter by means of a suitable test apparatus similar to that shown in Figure 7.

The deflection produced by this load shall be measured at a point directly below the centre of the indenter position at an accuracy of 0.01 mm at:

- i. The instant the load was applied.
- ii. 23 hours after the load was first applied.
- iii. 24 hours after the load was first applied and before removal of the load.
- iv. 2 hours after the load was removed.

Where deflection readings coincide with profile changes to the underside of the panel, then the average of two adjacent readings shall be recorded.

These readings shall be taken directly below the indenter position, to record deflections each side of the profile change.

When the profile change to the panel soffit extends beyond the area of the indenter position then the deflection readings shall be obtained from the top surface of the panel immediately adjacent to the indenter.

The average of the two readings shall be recorded as the deflection produced, see Figure 6a.

Any other deviation of the panel, particularly any upward movement at any unloaded edge shall be measured at the same time.

Two hours after removal of the load, the top surface of the panels shall be examined, and any indentation shall be measured. The test specimen shall also be examined for any other permanent deformation caused by the test load.

T8a.04 Test report

The test report shall include the following information:

- a. The structural grade of the system.
- b. Details of the support of the cut edge.
- c. The average environmental condition over the period of the test.
- d. Maximum permitted deflection or deviation: 1/250th of the span or 2.5mm whichever is the least.
- e. Deflection and deviation in the system after 23 hours.
- f. Deflection and deviation in the system after 24 hours.
- g. Difference between e. and f. (stability), Maximum 0.02 mm.
- h. Residual deflection 2 hours after removal of load, Maximum 0.5 mm.
- i. Permanent indentation of the top surface, Maximum 0.15 mm.
- j. Any other permanent or temporary deformation, deviation or damage to the system.

Figure 6a

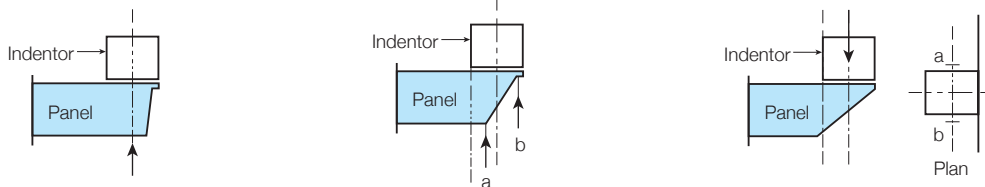

Detail 1

Directly below the centre of the indenter position

Detail 2

Average of two adjacent readings each side of the profile change and below the indenter position

$$\frac{a + b}{2} = \text{deflection produced}$$

Detail 3

Average of two readings immediately adjacent to the indenter on the top surface when the profile change to the panel soffit extends beyond the area of the indenter position

$$\frac{a + b}{2} = \text{deflection produced}$$

T9.00 | Four Point Loading Test

(Applies to extra heavy grade only)

T9.01

Test specimens

Two panels with eight pedestals selected at random. The specimens shall be of the maximum height of the type of system submitted.

P4.01

P4.02

T9.02

Mounting for test

The specimens shall be mounted as detailed for Test T7.00.

T9.03

Method of test

The indenter shall be four 25 mm steel cubes fixed to the corners of a 200 mm square steel plate at least 10 mm thick. It shall be weighed, and the force exerted by this weight shall be deducted from the applied load.

The indenter shall be applied:

- a. To the centre of the first panel.
- b. To the centre of edge of the second panel such that one edge of the indenter is contiguous with the panel edge and the centre lines of indenter and panel are coincidental.
- c. To an adjacent centre of edge of the second panel such that one edge of the indenter is contiguous with this edge and the centre lines of indenter and panel are coincidental.

A bedding in load, consisting of the test load shall be applied and maintained for a period of five minutes via the indenter and then released. An unloaded period of 5 minutes \pm 1 minute shall elapse before the commencement of the actual test and the zero-load deflection reading is taken.

A static load of 11 kN shall be applied and maintained for 24 hours at the centre of the indenter by means of a suitable test apparatus similar to that shown in Figure 7. The deflections produced by this load shall be measured to an accuracy of 0.01 mm at:

- a. The centre of the first panel,
- b. The centre of each loaded edge of the second panel at:
 - i. The instant the load was applied.
 - ii. 23 hours after the load was first applied.
 - iii. 24 hours after the load was first applied and before the removal of the load.
 - iv. 2 hours after the load was removed.

Two hours after removal of the load the top surface of the panels shall be examined and any indentation caused by the loaded indenter shall be measured. The test specimen shall also be examined for any other permanent deformation caused by the test load.

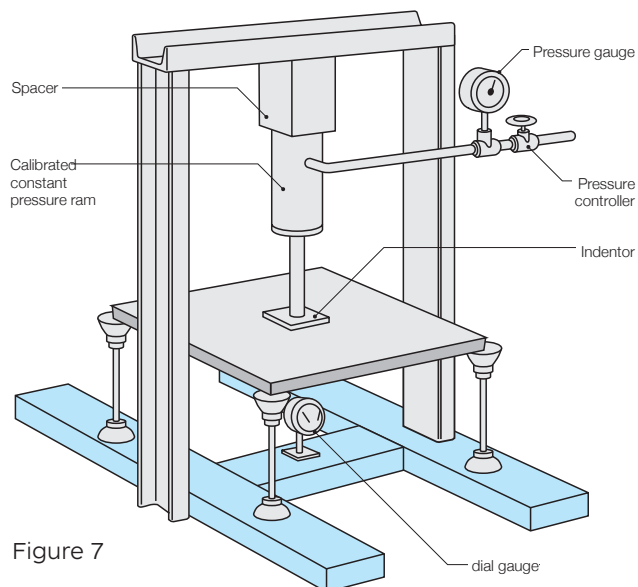

Figure 7

T9.00 | Four Point Loading Test

(Applies to extra heavy grade only)

T9.04

Test report

The test report shall include the following information:

- a. The structural grade of the system - Extra Heavy and the test load of 11 kN.
- b. The average environmental conditions over the period of the test.
- c. Maximum permitted deflection: 1 / 250th of the span or 2.5 mm whichever is the least.
- d. Deflection in the system after 23 hours of loading.
- e. Deflection in the system after 24 hours of loading.
- f. Difference between d and e (stability). Maximum 0.02 mm.
- g. Residual deflection 2 hours after the load was removed. Maximum 0.5 mm.
- h. Permanent indentation of the top surface. Maximum 0.15 mm.
- i. Any other permanent deformation in the system.

Note: Results d to i are required for each test position.

T10.00 | Uniformly Distributed Load Test

(Applies to all structural grades)

T10.01

Test specimen

One panel with four pedestals selected at random. The specimen shall be of the maximum height of the type of system submitted.

P4.01
P4.02

T10.02

Mounting test

The specimen shall be mounted as detailed for Test T7.00.

T10.03

Method of test

The particular uniformly distributed static load specified in Clause P4.01 shall be applied by means of a ram and spreader plates to the top surface of the panel. The spreader plates shall be as detailed in Figure 7a and 7b. The spreader plates shall be weighed, and the force exerted by this weight shall be deducted from the applied load. A bedding-in load, consisting of the test load shall be applied and maintained for a period of five minutes via the spreader plates and then released. An unloaded period of 5 minutes \pm 1 minute shall elapse before the commencement of the actual test and zero load deflection is taken.

The test load shall be applied and maintained for 24 hours.

The deflections produced by this load shall be measured to an accuracy of 0.01 mm at:

- a. The centre of panel and
- b. The centre of each edge of the panel to record the maximum deflection produced
 - i. The instant the load was applied.
 - ii. 23 hours after the load was first applied.
 - iii. 24 hours after the load was first applied and before the removal of the load.
 - iv. 2 hours after the load was removed.

Two hours after the removal of the load the specimen shall be examined for any permanent deformation caused by the test load.

T10.00 | Uniformly Distributed Load Test

(Applies to all structural grades)

T10.04 Test report

The test report shall include the following information:

- The structural grade of the system - Light, Medium, Heavy or Extra Heavy and the test load.
- The average environmental conditions over the period of the test.
- Maximum permitted deflection: 1/250th of the span or 2.5 mm whichever is the least.
- Deflection in the system at centre and centre of edge of panel after 23 hours loading.
- Deflection in the system at centre and centre of edge of panel after 24 hours loading.
- Difference between d and eat centre and centre of edge (stability). Maximum 0.02 mm.
- Residual deflection at the centre and centre of edge of panel 2 hours after the load was removed. Maximum 0.5 mm.
- Any other permanent deformation in the system.

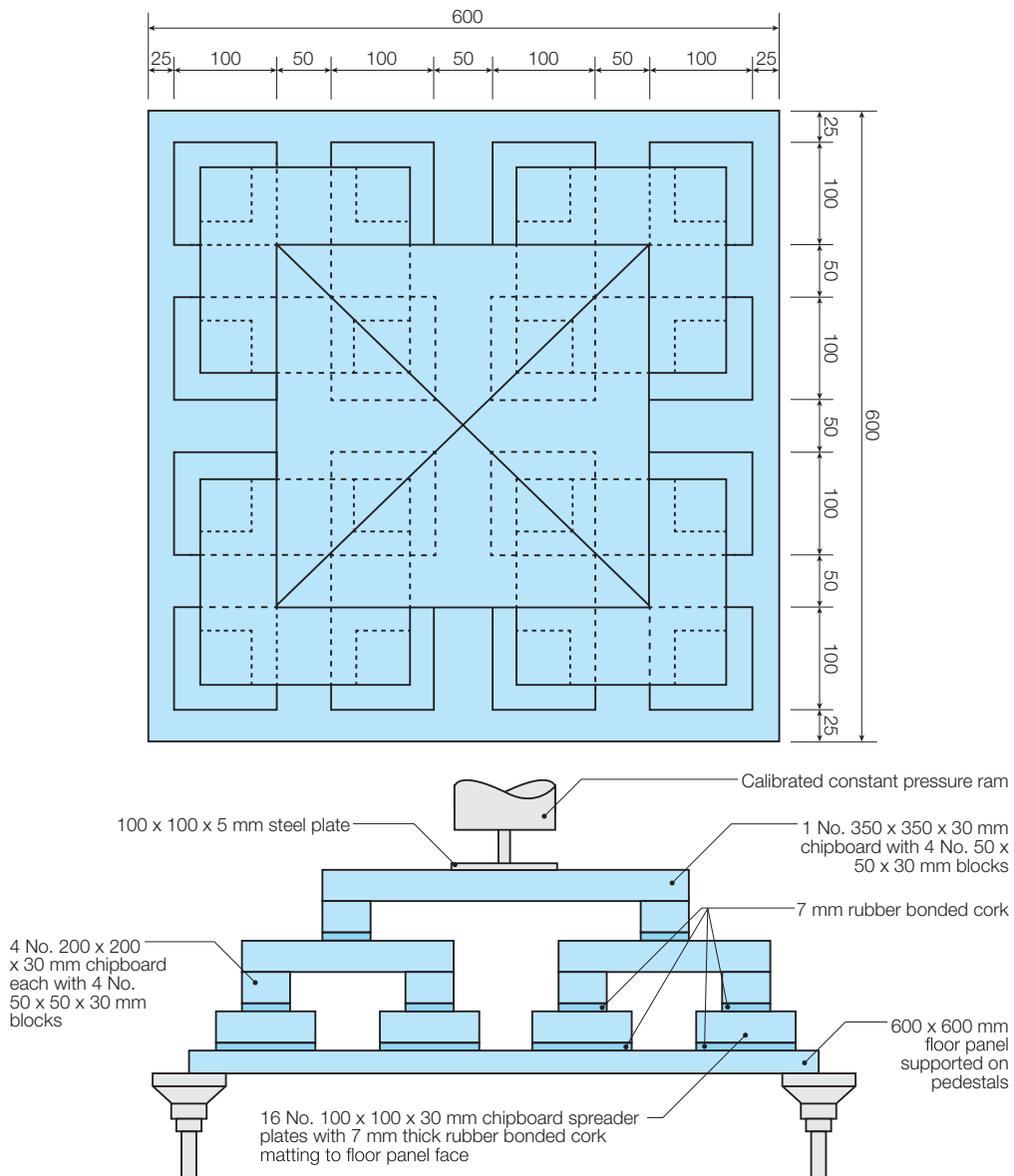
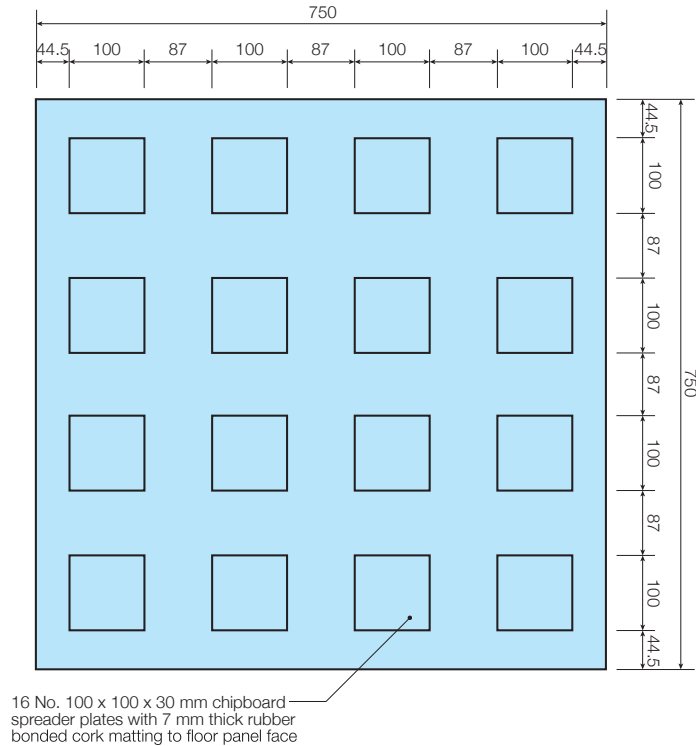

Figure 7a: Detail of UDL Spreader Plates for 600 x 600 panels

T10.00 | Uniformly Distributed Load Test (Applies to all structural grades)



Method of load application shall be similar to that detailed for a 600 mm x 600 mm full access panel but with suitably sized loading plates i.e. 4 No. 237 mm x 237 mm and 1 No. 374 mm x 374 mm
See Figure 7a.

Figure 7b: Detail of UDL Spreader Plates for 750 x 750 panels

T11.00 | Safety Factor Load Tests (Applies to all structural grades)

T11.01 Test specimens

The panels and pedestals used in Tests T7.00, T8.00, T8a.00 T9.00 and T10.00.

P4.03

T11.02 Mounting for test

The specimens shall be mounted as in Tests T7.00, T8.00, T8a.00 T9.00 and T10.00.

T11.03 Method of test

- a. Using the particular indentors on the positions specified for Tests T7.00, T8.00 and T8a.00 and the spreader plates specified for Tests T10.00, a load equal to THREE times that specified for those tests shall be applied and maintained for a period of five minutes and then removed.
- b. Using the particular indenter on the positions specified for Test T9.00, a load equal to TWO times that specified for that test (22 kN) shall be applied and maintained for a period of five minutes and then removed.

The safety factor load shall be applied to the centre of edge positions which deflected the greatest during the static load tests.

T11.00 | Safety Factor Load Tests (Applies to all structural grades)

T11.04 Test report

The test report shall include the following information:

- The structural grade of the system - Light, Medium, Heavy or Extra Heavy and the test load.
- The environmental conditions at the time of the test.
- A statement that the system DID or DID NOT collapse.
- A report of the collapse characteristic if applicable, or any other deformation.

T12.00 | Soft Body Impact Test

T12.01 Test specimen

One panel with four pedestals selected at random. The specimen shall be of the maximum height of the type of system submitted.

P4.04

T12.02 Mounting for test

The specimen shall be mounted as detailed for Test T7.00.

T12.03 Method of test

A canvas bag 600 mm high with a 300 mm dia. base containing dry sand to a mass of 40 kg. The filled bag shall be dropped on to the specimen from a height of 1 metre. The first drop shall make contact upon the centre of the panel and the second drop shall make contact with the centre of one edge of the panel with the whole base of the bag coming into contact with the panel. The specimen should not collapse on or after impact, but careful observation shall be made to determine whether any damage has occurred. See Figure 8.

T12.04 Test report

The test report shall include the following information:

- The module size of the panel and height of the system.
- The environmental conditions at the time of the test.
- A statement that the system DID or DID NOT collapse.
- A report of the collapse characteristic, if applicable or of any other deformation.

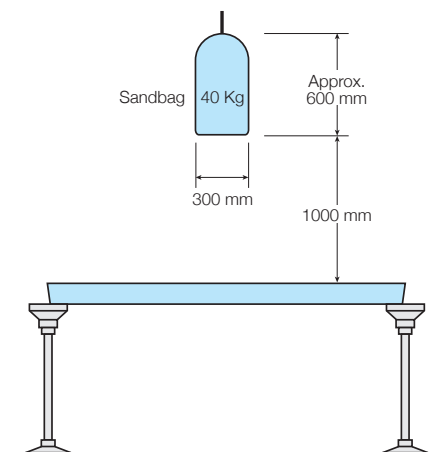

Figure 8

T13.00 | Hard Body Impact Test

T13.01

Test specimen

One panel with four pedestals selected at random. The specimen shall be of the maximum height of the type of system submitted.

P4.04

T13.02

Mounting for test

The specimen shall be mounted as detailed for Test T7.00.

T13.03

Method of test

A steel indenter weighing 4.5 kg with a 50 mm hemispherical end shall be dropped on to the specimen from a height of 600 mm. The first drop shall be on to the centre of the panel, the second drop shall be on to the centre of one edge of the panel, the third drop shall be on to the centre of an adjacent edge of the panel and the fourth drop shall be on to a point 50 mm from a corner of the panel on the diagonal. The specimen should not collapse on or after any impact, but careful observation shall be made to determine whether any damage has occurred. See Figure 9.

T13.04

Test report

The test report shall include the following information:

- The module size of the panel and height of the system.
- The environmental conditions at the time of the test.
- A statement that the system DID or DID NOT collapse.
- A report of the collapse characteristic, if applicable or of any other deformation.

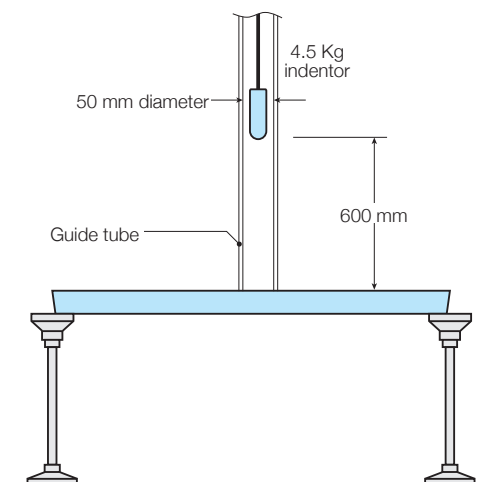

Figure 9

T14.00 | Pedestrian Dynamic Load Test

T14.01

Test specimen

P4.05

Two panels without floor covering selected at random, one of which shall be cut in half parallel to one of the sides and eight pedestals sized and set to provide a floor level of 300 mm from the substrate to the top of the panel. If the system submitted is less than 300 mm then the system set to the actual height shall be tested.

T14.02

Mounting for test

The panels and pedestals shall be mounted in a testing apparatus similar to that shown in Figure 10. The pedestals shall be bonded on to a rigid substrate by means of the adhesive and any mechanical fixings submitted by the manufacturer. The test shall be commenced 48 hours \pm 5 hours after the adhesive was first applied. The specimen shall be mounted such that the centre of the full panel is beneath the centre of the indenter and the two half panels being mounted contiguous with opposite edges of the full panel. The ends of each half panel shall be restrained by clamping screws which will bear on to a 3mm x 25mm x 600mm or 750mm length of steel strip between the cut edge of the panel and the clamping screws. A gap of 0.5mm shall be set at each end. Two 0.5mm thick shims are a convenient method of setting these gaps.

T14.03

Method of test

An indenter consisting of a steel plate 100 mm diameter and not less than 10mm thick on top of a 100mm diameter x 3mm thick piece of vulcanised rubber of 70° to 90° Shore A Hardness shall be actuated by a mechanism capable of exerting vertical and horizontal forces on the specimen.

The specimen shall be subjected to 250,000 loading cycles through the indenter, each cycle shall consist of the following:

- 0 seconds Apply a downward vertical force of 1 kN.
- 1 second Apply a horizontal force of 170 N first in one longitudinal direction of the assembly and secondly in the opposite direction.
- 2 seconds Remove the downward vertical force.
- 3 seconds Apply a downward vertical force of 1 kN and so on.

The specimen shall be allowed to bed for 100 cycles and the 0.5mm gap shall be reset. The horizontal movement of the full panel and the vertical movement of the full panel shall be measured over the next 10 cycles. After 249,990 cycles, the horizontal and vertical movements of the full panel shall be measured over a further 10 cycles. All measurements shall be to an accuracy of 0.01mm.

T14.04

Further test on specimen

After the completion of the dynamic load test, the full panel shall be subjected to the point load test detailed for Test T8.00 on the centre of the panel only. The load shall be that specified for the particular structural grade undergoing the test. The deflections produced shall be within the requirements detailed in Clause P4.02.

T14.05

Test report

The test report shall include the following information:

- a. The structural grade of the system - Light, Medium, Heavy, Extra Heavy and the test load for the point load test.
- b. The module size of the panels and the height of the system.
- c. The average environmental conditions over the period of test.
- d. Mean horizontal movement over the first 10 cycles (after the 100 bedding cycles). Maximum 1.5 mm.
- e. Mean vertical deflection over the first 10 cycles. Maximum 1 mm.
- f. Mean horizontal movement over the last 10 cycles. Maximum 1.5 mm.

T14.00 | Pedestrian Dynamic Load Test

T14.05

- g. Mean vertical deflection over the last 10 cycles. Maximum 1 mm.
- h. Increase in horizontal movement between d. and f. Maximum 0.5 mm.
- i. Increase in vertical deflection between e. and g. Maximum 0.33 mm.
- j. Report of all information required by Test T8.00.
- k. Report of any wear, de-lamination, cracking or any other deterioration.

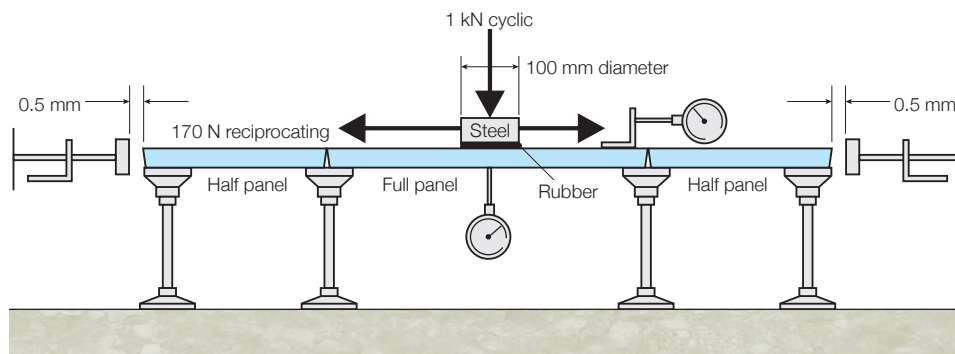

Figure 10

T15.00 | Pedestal Strength - Horizontal Load

T15.01

Test specimen

Two pedestals which shall be at the maximum height of the type of system submitted.

P4.07

T15.02

Mounting for test

The pedestals shall be bonded to a rigid substrate by means of the adhesive and any mechanical fixings submitted. The pedestals shall be free standing without support from stringers, panels or other similar devices. The pedestals shall be adjusted to the maximum recommended height. The test shall be commenced 48 hours \pm 5 hours after the adhesive was first applied.

T15.03

Method of test

A steady horizontal moment of 90 Nm, within the range of applied loads from 9kg minimum to 50kg maximum, shall be applied to the uppermost part of the pedestal for 5 minutes and then released. After removal of the force, permanent deformation, if any, shall be measured at the top of the pedestal to an accuracy of 0.01 mm.

The specimen shall be inspected for any sign of failure of the bond between the pedestal base and the substrate. The method of attachment of the force shall be at the discretion of the testing authority. See Figure 11.

T15.00 | Pedestal Strength - Horizontal Load

T15.04

Test report

The test report shall include the following information:

- Height of the pedestals.
- Load applied in kilograms. Maximum 50 kg. Minimum 9kg.
- Permanent deformation.
- Permanent deformation per 100 mm in height.
- Report of any detachment of pedestal base from substrate including detail of failure i.e. failure of bond or substrate.

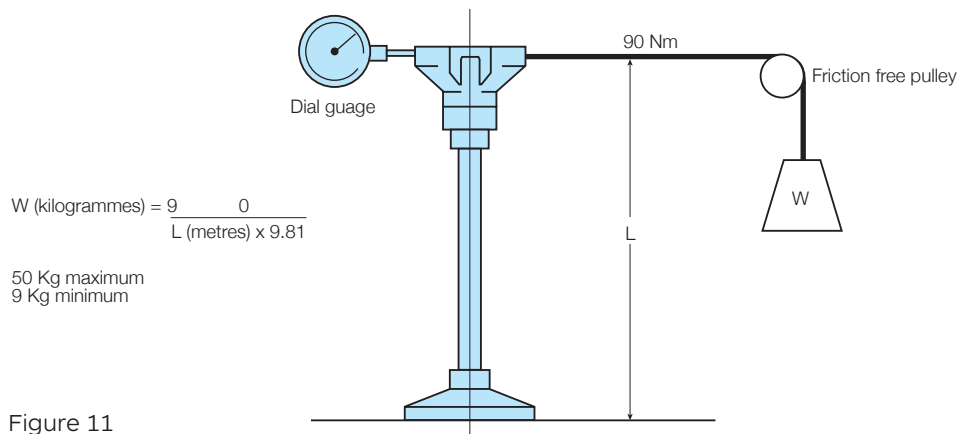

T16.00 | Pedestal Strength - Vertical Load

T16.01

Test specimen

Four pedestals which shall be at the maximum height of the type of system submitted.

P4.07

A full panel and three-part panel corners are required.

T16.02

Mounting for test

The pedestals shall be bonded on to a rigid substrate by means of the adhesive and any mechanical fixings submitted. The pedestals shall be adjusted to the maximum recommended height and the full panel set up level on the four pedestals. The test shall be commenced 48 hours ± 5 hours after the adhesive was first applied.

The pedestals shall be fitted with the part panel comers applicable to the particular test:

Test a. One full panel with three-part panel corners.

Test b. One full panel only

T16.03

Method of test

Test a.

At the centre of the pedestal head. See Figure 12. Two pedestals shall be subjected to this test. The specified load of 10.8 kN for Light grade or 18 kN for Medium, Heavy and Extra Heavy grades shall be applied and maintained through a 50 mm x 50 mm indenter located over the centre of the pedestal head via the full panel and the three part panel corners fitted to the head as they would be in service for a period of five minutes and then removed.

During the period of loading, the pedestal should not collapse.

T16.00 | Pedestal Strength -Vertical Load

T16.03

Method of test

Test b.

Over one quadrant of the pedestal head. See Figure 12.

The remaining two pedestals shall be subjected to this test. The specified load of 8.1kN for Light grade or 9kN for Medium, and 13.5kN Heavy and Extra Heavy grades shall be applied and maintained through a 50mm x 50mm indenter located over a corner of the full panel through to the quadrant of the pedestal head for a period of five minutes and then removed.

During the period of loading the pedestal should not collapse.

T16.04

Test report

The test report shall include the following information:

- The structural grade of the system - Light, Medium, Heavy or Extra Heavy and the test loads.
- A statement that the pedestals DID or DID NOT collapse.
- A report of the collapse characteristic if applicable or of any other deformation.

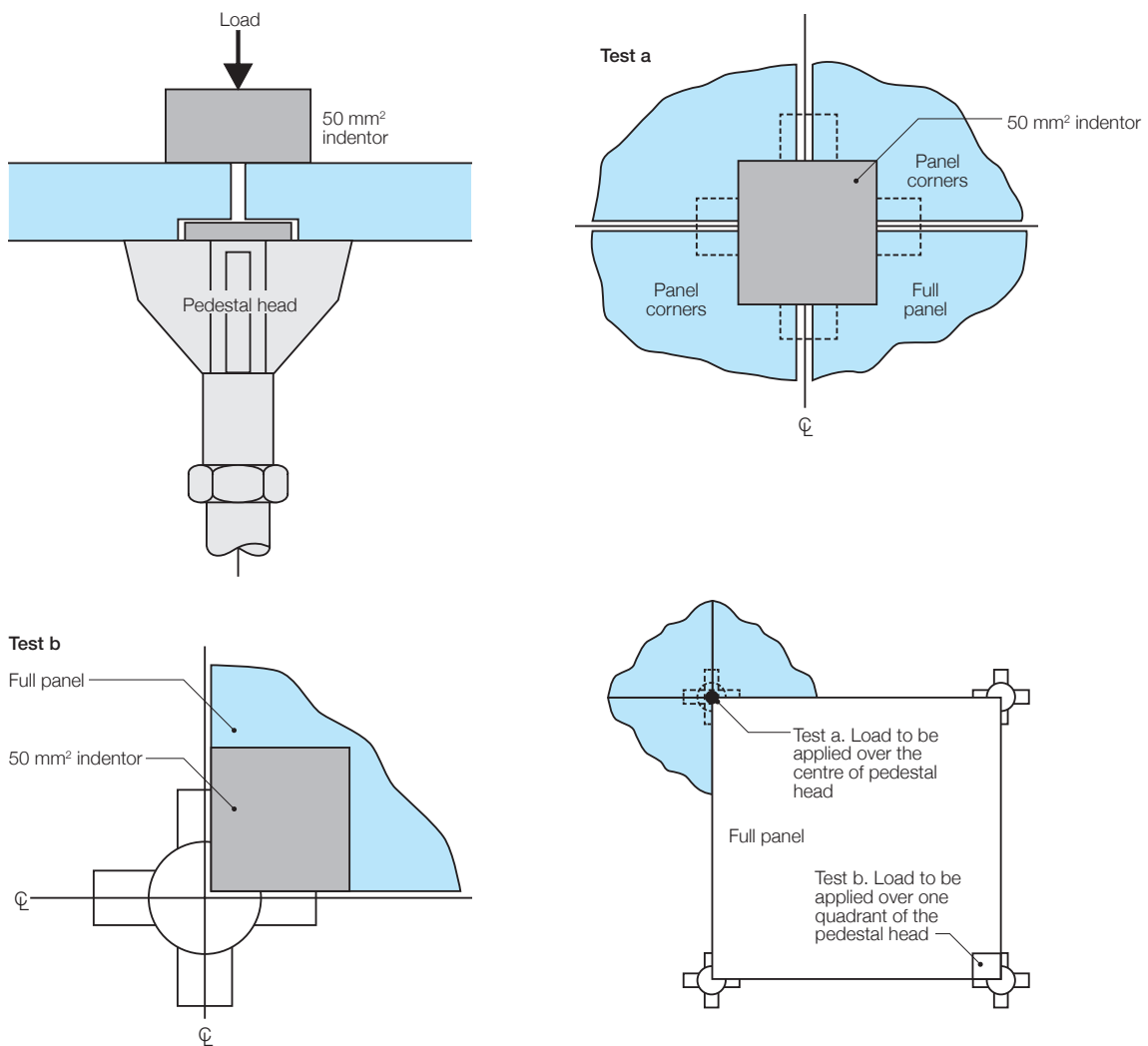

Figure 12

T17.00 | Effect of Temperature

T17.01

Test specimen

One panel without floor covering selected at random from samples submitted.

P5.02

T17.02

Mounting for test

The specimen shall be tested unmounted.

T17.03

Method of test

The concavity, convexity, twist and squareness of the panel shall be measured as detailed for tests T1.00, T2.00 and T3.00.

The panel shall be placed flat with the edges supported in an air circulating oven/refrigerator which shall be capable of maintaining the specified temperature to within ± 1 °C Dry bulb. If more than one panel is to be conditioned, it shall be separated from its neighbour by at least 25 mm.

The panel shall be conditioned at 5 °C dry bulb for 14 days (336 hours) continuously after which the change in concavity, convexity and twist shall be ascertained by measurement as detailed for tests T1.00 and T2.00.

The panel shall then be conditioned at 30 °C dry bulb for 14 days (336 hours) continuously after which the change in concavity, convexity, twist and squareness shall be ascertained by measurement as detailed for tests T1.00, T2.00 and T3.00. After each conditioning period the panel shall be examined for any de-lamination of materials or components.

Twenty four hours ± 1 hour after completion of the foregoing conditioning, the panel shall be subjected to the 25 mm x 25 mm point load test as detailed for test T8.00 on the position which produced the greatest deflection in test T8.00 which may necessitate the testing of two adjacent centre of edges.

T17.04

Test report

The test report shall include the following information:

- a. Dimensional deviations (tests T1, T2 and T3) before conditioning.
- b. Dimensional deviations (tests T1, T2 and T3) after 14 days@ 5 °C.
- c. Dimensional deviations (tests T1, T2 and T3) after 14 days@ 30 °C.
- d. Dimensional changes (T1, T2 and T3) after each conditioning period.
- e. Report of any de-lamination of materials or components.
- f. Any other deterioration of the panel.
- g. All information required by test T8.00.

T18.00 | Effect of Humidity

T18.01

Test specimen

One panel without floor covering selected at random from samples submitted.

P5.02

T18.01

Mounting for test

The specimen shall be tested unmounted.

T18.01

Method of test

The concavity, convexity, twist and squareness of the panel shall be measured as detailed for tests T1.00, T2.00 and T3.00.

The panel shall be placed flat with the edges supported in a conditioning cabinet which shall be capable of maintaining the specified temperature to within ± 1 °C and a humidity sensitivity of $\pm 2.0\%$ RH.

T18.00 | Effect of Humidity

If more than one panel is to be conditioned, it shall be separated from its neighbour by at least 25 mm.

The panel shall be conditioned at 23 °C 25% RH for 14 days (336 hours) continuously after which the change in concavity, convexity and twist shall be ascertained by measurement as detailed for Tests T1.00 and T2.00.

The panel shall then be conditioned at 23 °C 75% RH for 14 days (336 hours) continuously after which the change in concavity, convexity, twist and squareness shall be ascertained by measurement as detailed for tests T1.00, T2.00 and T3.00. After each conditioning period the panel shall be examined for any de-lamination of materials or components.

Twenty four hours \pm 1 hour after completion of the foregoing conditioning, the panel shall be subjected to the 25 mm x 25 mm point load test as detailed for Test T8.00 on the position which produced the greatest deflection in Test T8.00

T18.04

Test report

The test report shall include the following information:

- a. Dimensional deviations (Test T1, T2 and T3) before conditioning.
- b. Dimensional deviations (Test T1, T2 and T3) after 14 days@ 23°C 25% RH.
- c. Dimensional deviations (Test T1, T2 and T3) after 14 days@ 23°C 75%RH.
- d. Dimensional changes (T1, T2 and T3) after each conditioning period.
- e. Report of any delamination of materials or components.
- f. Any other deterioration of the panel.
- g. All information required by test T8.00.

T19.00 | Determination of Surface Spread of Flame & Index of Performance (Fire)

T19.01

Test specimen

The specimens for the Surface Spread of Flame test shall comprise six representative full-length panel sections up to 900 mm long x 230 mm wide. The specimens for the Index of Performance tests shall comprise six representative panel sections 228 mm x 228 mm. All specimens shall be of the normal panel thickness and all materials, including adhesives, core material and protective finishes shall be exactly as used in production. The attachment of any cladding to the core material shall simulate, as nearly as possible, the final installation condition, e.g. if the cladding is kept in contact with the core material by pedestals, then it shall be permissible to use a small mechanical fixing at each corner only. If the cladding is not held in place by the pedestals, then there shall be no extra mechanical fixing allowed.

P6.02

T19.02

Method of test

The tests shall be performed on the void side of the specimens only, exactly in accordance with the methods specified in BS476: Pt.6: Index of Performance and BS476: Pt.7: Spread of Flame.

T19.03

Test report

The results shall be reported as required by BS476: Pt.6 and BS476: Pt.7. In addition, any detachment of the cladding from the core material shall be reported.

T20.00 | Small Scale Fire Test

T20.01

Test specimen

P6.05

Five panels without floor covering selected at random one of which shall be cut in half parallel to one of the sides and twelve pedestals which shall be set to provide a cavity height of 300 mm or set to the maximum height if the system under test has a cavity of less than 300 mm.

T20.02

Mounting for test

The panels shall be mounted on the pedestals to give a floor two panels wide x two and a half panels long. The pedestals shall be fixed to a concrete sub floor by means of the adhesive and/or fixings proposed. If the pedestals are less than 300 mm high, then they shall be mounted and fixed to non-combustible blocks 150 mm square of a suitable height to provide a cavity height of 300 mm. The blocks shall be suitably fixed to the concrete sub floor. The fixing adhesive, if any shall be allowed to set for a period of 48 hours ± 5 hours before commencement of the test.

The specimen shall be surrounded by an insulation block wall 450 mm high. There shall be three ventilation ports 225 mm high x 50 mm wide on each of the longer sides of the enclosure and two ventilation ports of a similar size on each of the shorter sides. These ports shall be protected from any external air movement by means of 450 mm high x 225 mm wide shields placed in front of the ports 25 mm from them. See Figure 14 for arrangement.

T20.03

Method of test

The source of ignition shall be a crib fire constructed from 1070g ± 30g of 25 and 32mm square rough sawn softwood with a moisture content of 10% to 15%. The crib shall be constructed as shown in Figure 13. It shall be fired by approximately 25 to 30 g of wood wool placed underneath. The crib shall be placed under the floor as near as possible to a pedestal as shown in Figure 14.

However, if in the opinion of the test authority any other position under the specimen is considered to be a point of weakness with regard to fire resistance, an additional test shall be carried out at that point.

A uniformly distributed load equal to the requirement for the particular system detailed in Clause P4.01 shall be applied to the specimen as shown in Figure 14. Instruments shall be set up to measure the deflection of the corner of the panel over the pedestal adjacent to the crib fire and at the mid span on the edge of that panel to an accuracy of 0.01 mm.

The crib shall be lit and allowed to burn for the test period of 30 minutes. Observations shall be made of the system within the void which shall be viewed through the ventilation ports and deflection measurements taken and recorded at 60 second intervals.

T20.04

Test report

The test report shall include the following information:

- a. The structural grade of the system and the uniformly distributed load.
- b. Panel size and pedestal height.
- c. The environmental conditions at the time of test.
- d. The maximum deflection at both positions.
- e. A report of the visual observations including displacement of metal cladding on the underside, burning or melting of any of the constituent materials of the panels and supporting structure, any smoke or toxic fumes.
- f. Observations made on the specimen after the completion of the test.

T20a.00 | Thermal Properties

T20a.01

Test specimen

P6.08

Two panels without floor covering selected at random shall be mounted on six standard pedestals to give a floor area two panels long x one panel wide, to simulate a central area of a typical installation.

The pedestals shall be set to provide a cavity height of 300mm or set to the maximum height if the system under test has a cavity of less than 300mm.

T20a.02

Mounting for test

The pedestals shall be fixed to a concrete sub floor by means of the adhesive and/or fixings proposed.

If the pedestals are less than 300mm high, then they shall be mounted and fixed to non-combustible blocks 150mm square of a suitable height to provide a cavity height of 300mm. The blocks shall be suitably fixed to the concrete sub floor.

The fixing adhesive, if any, shall be allowed to set for a period of 48 hours \pm 5 hours before commencement of the test.

The specimen shall be surrounded by an insulation block wall laid dry and to a nominal height of 415mm. There shall be four ventilation ports on each of the longer sides of the enclosure and two ventilation ports on each of the shorter sides. Each ventilation port shall be nominally 315mm high x 50mm wide. See Figure 14a.

T20a.03

Method of test

The source of ignition shall be a crib fire constructed from 1070g \pm 30g of 25mm and 32mm square rough sawn softwood with a moisture content of 10% to 15%. The crib shall be constructed as shown in Figure 13. It shall be fired by 25 to 30g of wood wool placed underneath.

The crib shall be placed under the floor at the centre of the mid-point of the joint.

Nine fixed thermocouples shall be located on the top surface of each panel to measure the mean face temperature of the unexposed face as shown in Figure 14b. A further thermocouple (nineteenth) shall be located on either panel top surface, in any position of free area, which will, in the opinion of the test Authority, record the maximum surface temperature.

Thermocouples shall be attached to the panel surface by the method defined in BS 476: Part 20. All thermocouple readings shall be included in the analysis of test results.

The temperatures shall be recorded on a strip chart recorder or similar apparatus.

The crib shall be lit and allowed to burn for the test period of 30 minutes.

T20a.04

Test report

The test report shall include the following information:

- a. The structural grade of the system.
- b. Panel size and pedestal height.
- c. The environmental conditions at the time of the test.
- d. The position on the panel surface of the nineteenth thermocouple.
- e. Maximum top surface temperature.
- f. Mean top surface temperature.
- g. A report of the visual observations including displacement of metal cladding on the underside, burning or melting of any of the constituent materials of the panels or supporting structure.
- h. A statement that the test results of this system are indicative only.

T20a.00 | Thermal Properties (Full Access Systems)

Wood sticks comprising 10 x 25mm square and 6 x 32mm square each 200mm long sawn softwood with moisture content of 10 to 15%. Crib to be assembled with small quantity of PVA wood adhesive.

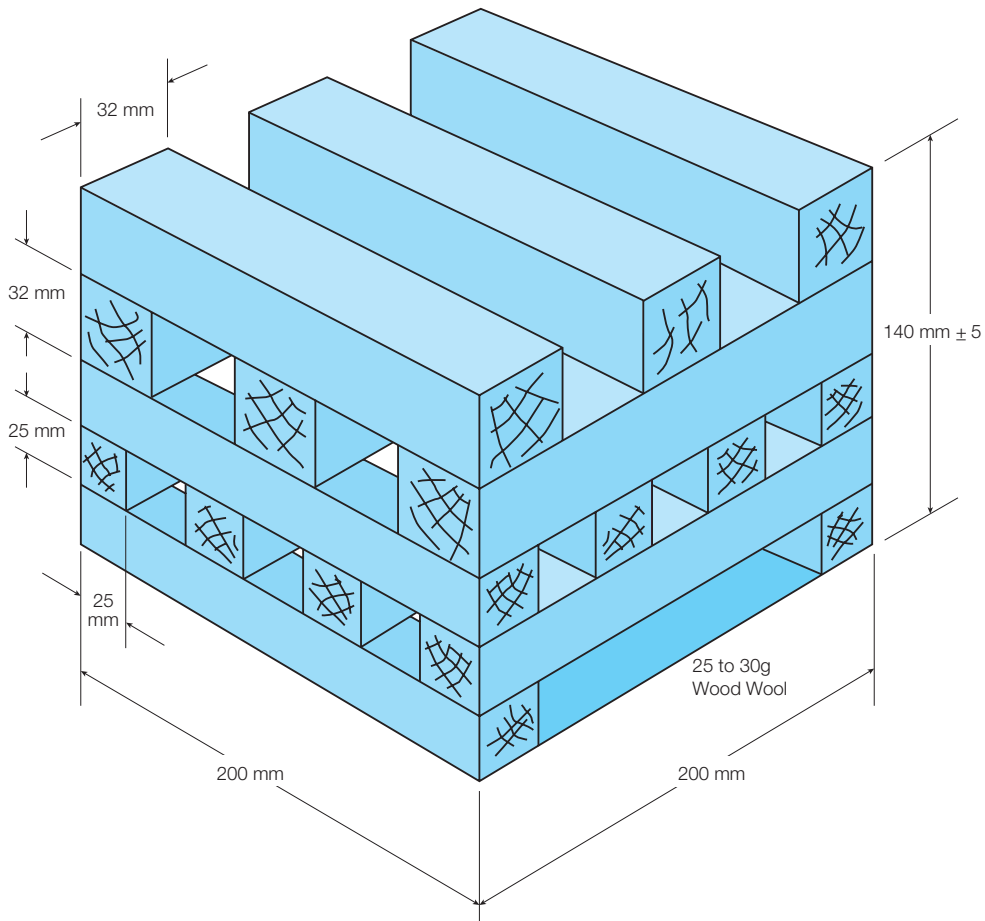

Figure 13 1070g ± 30g Fire Crib

T20a.00 | Thermal Properties (Full Access Systems)

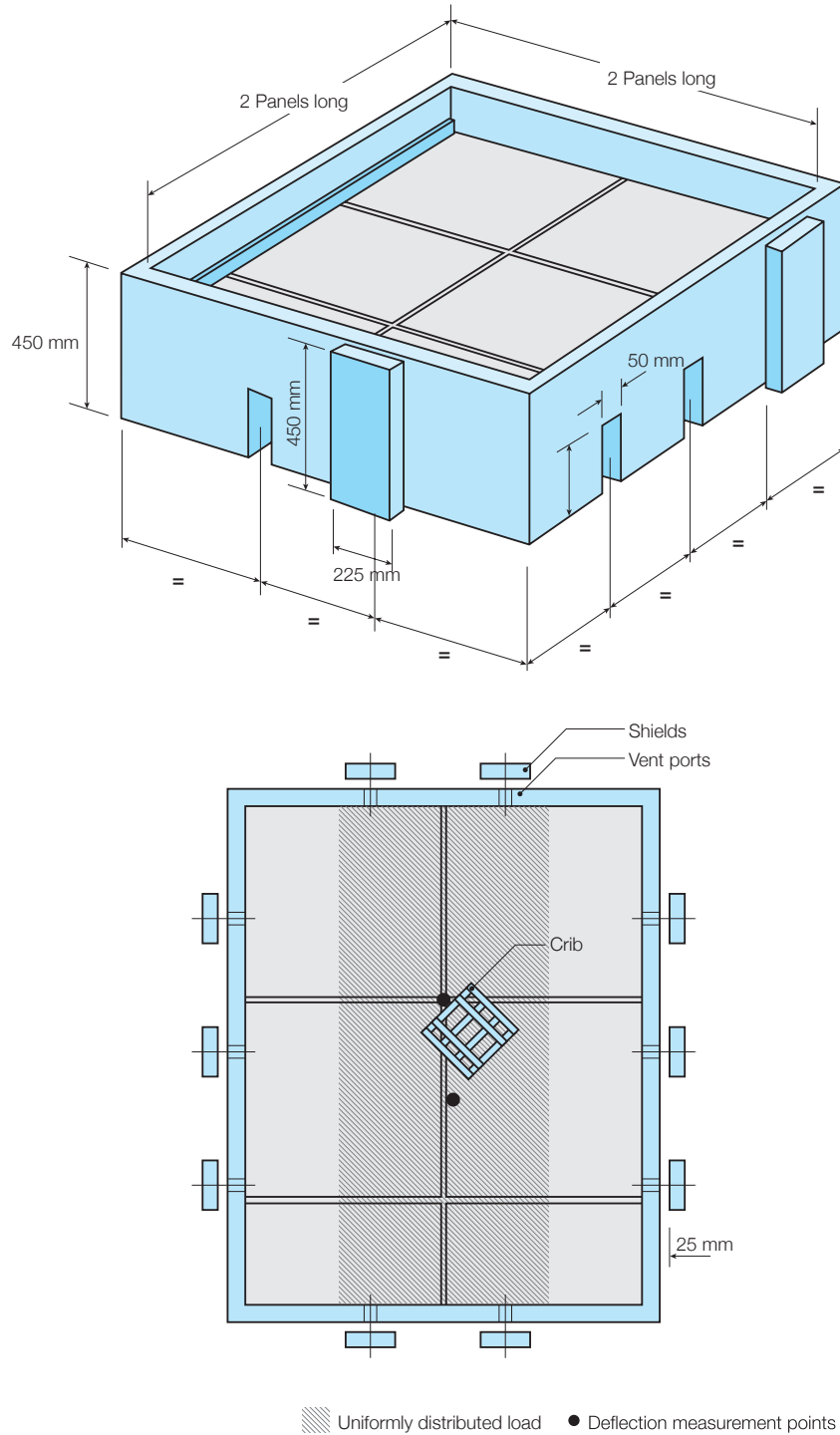

Figure 14 Arrangement of Small-Scale Fire Test (Full Access)

T20a.00 | Thermal Properties

(Full Access Systems)

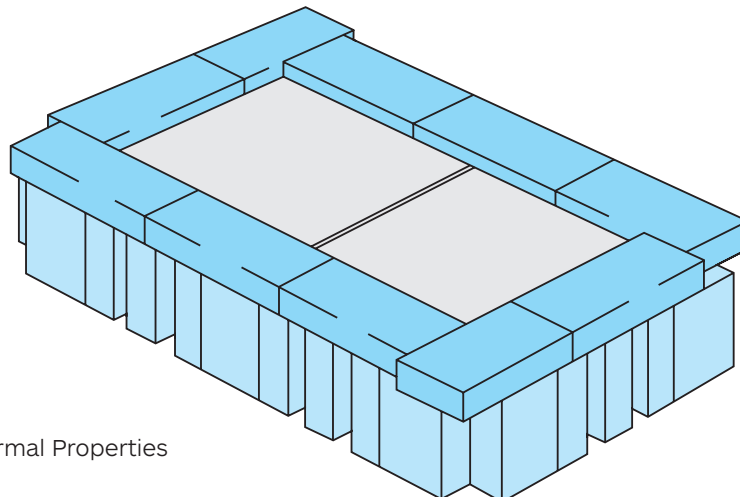
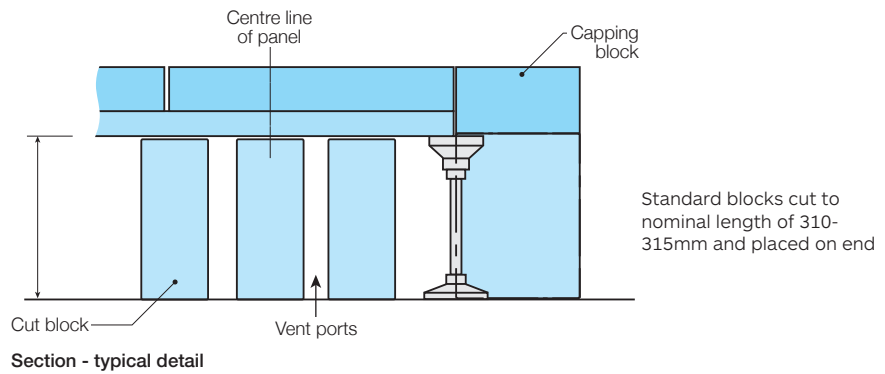
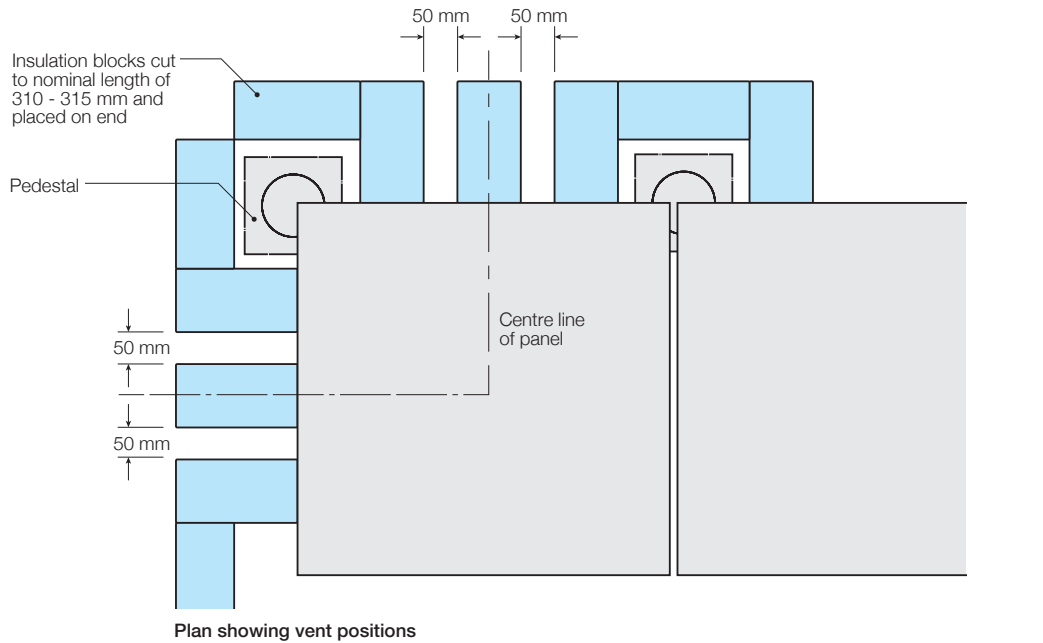

Figure 14a Thermal Properties

T20a.00 | Thermal Properties

(Full Access Systems)

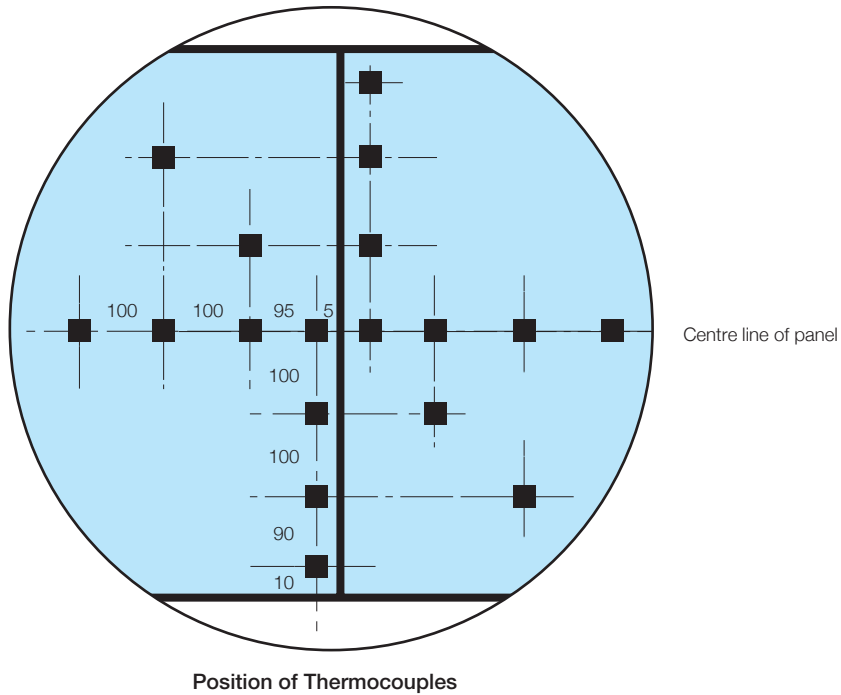
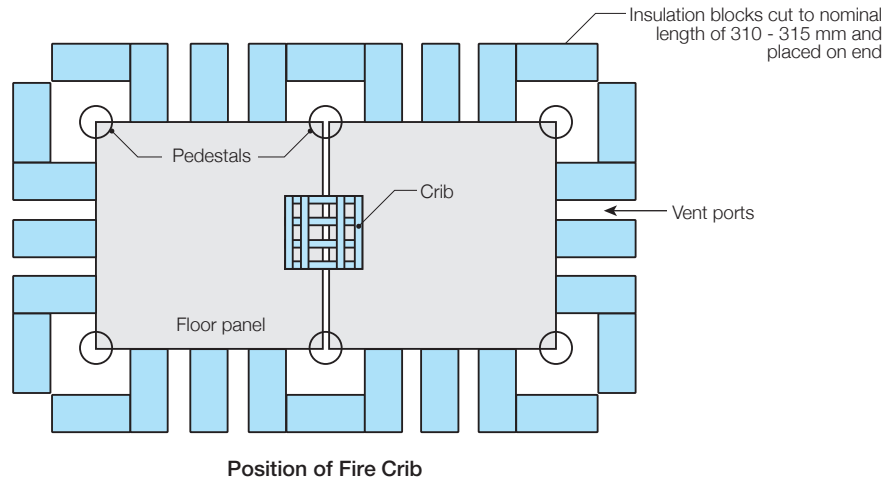

Figure 14b Location of Thermocouples

T21.00 | Test Specimens

T21.01

Test specimen for tests T23.00, T29.00, T30.00, T31.00, T32.00, T33.00, T34.00, T35.00, T36.00, T37.00, T38.00 and T39.00

The specimen on which all tests detailed in clauses T23.00, T29.00, T30.00, T31.00, T32.00, T33.00, T34.00, T35.00, T36.00, T37.00, T38.00 and T39.00 are to be carried out shall consist of an area of flooring nominally 2400 mm x 2400 mm mounted on the applicable pedestals to provide the maximum height of floor level of the type of system submitted.

Two access panels are to be included in the specimen which shall be generally as shown in Figure 15.

The specimen shall be erected on a suitable concrete sub floor at the laboratory and shall simulate as nearly as possible a true "in service" condition. In particular, the perimeter and the access panels shall be installed as would normally be "in service" e.g. with additional pedestals or support structures.

The panel sizes and joint positions shown in Figure 15 are not mandatory and the manufacturer may submit a specimen with panel sizes to suit his particular system. In which case the test positions must be similar to those shown on the drawing and detailed in the text.

The tests which are to be conducted on this 2400 mm x 2400 mm area of flooring shall be carried out in the following order:

T23.00	Panel levels and panel flatness	Fixed panels only.
T29.00	300 mm square loading test	Various areas may be tested simultaneously at the discretion of the testing authority.
T30.00	Point loading test	
T31.00	Uniformly distributed load test	
T34.00	Pedestrian dynamic load test	
T32.00	Soft body impact test	Using spare access panel.
T33.00	Hard body impact test	Using further spare access panel.
T35.00	Pedestal strength - Horizontal load	
T36.00	Pedestal strength - Vertical load	Using spare access panel.
T37.00	Effect of temperature	The access panel shall be installed in the access orifice which was not used for the pedestal loading tests.
T38.00	Effect of humidity	The access panel shall be installed in the access orifice which was not used for the pedestal loading tests.
T39.00	Safety factor load tests	Pedestals which were subjected to tests T35 and T36 to be replaced.

T21.00 | Test Specimens

T21.02

Specimens for all other tests

The specimens for all other tests shall be as detailed in the particular test clause.

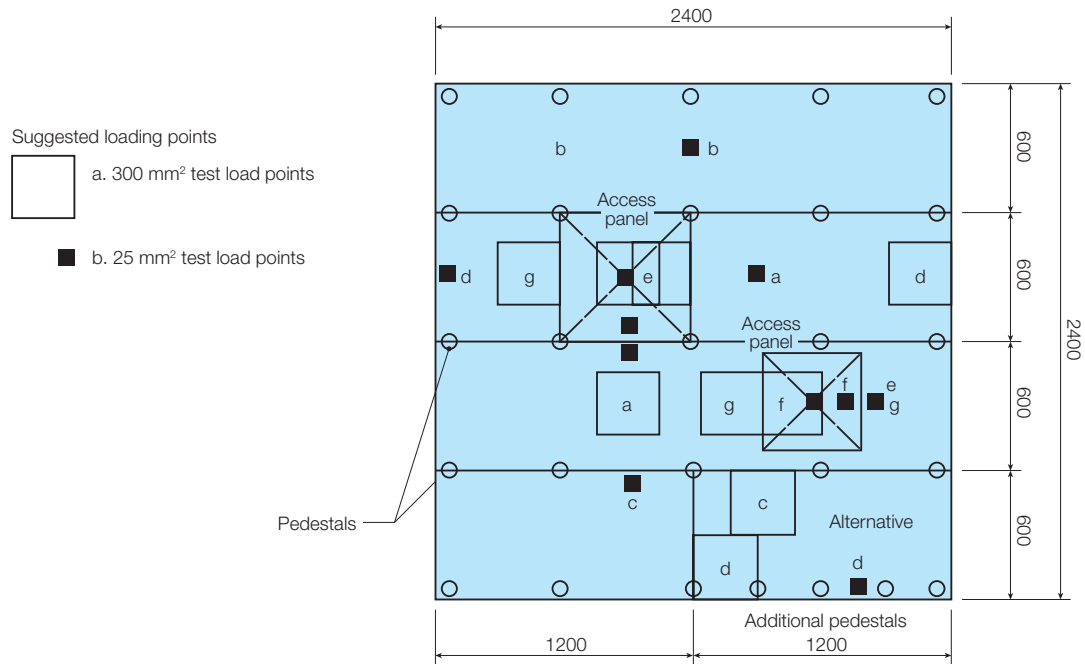

Figure 15 Detail of 2400mm x 2400mm area of flooring

T22.00 | Concavity & Convexity: Removable Access Panels Only

T22.01

Test specimen

Four removable access panels of each size proposed for the type of system submitted.

P3.09
P5.02

T22.01

Mounting for test

Each panel shall be mounted in turn in the particular access aperture in the 2400 mm x 2400 mm test specimen.

T22.01

Method of test

The concavity or convexity shall be measured across the two diagonals and at four points equidistant across the panel parallel to two opposite edges. The measurements shall be determined using a bridge and dial gauge to an accuracy of 0.01 mm. See Figure 16.

T22.01

Test report

The test report shall contain the following information:

- The size of the access panel.
- The environmental conditions at the time of measurement.
- The maximum concavity or convexity of each panel.
- The specified limit of 0.75 mm maximum.

T22.00 | Concavity & Convexity: Removable Access Panels Only

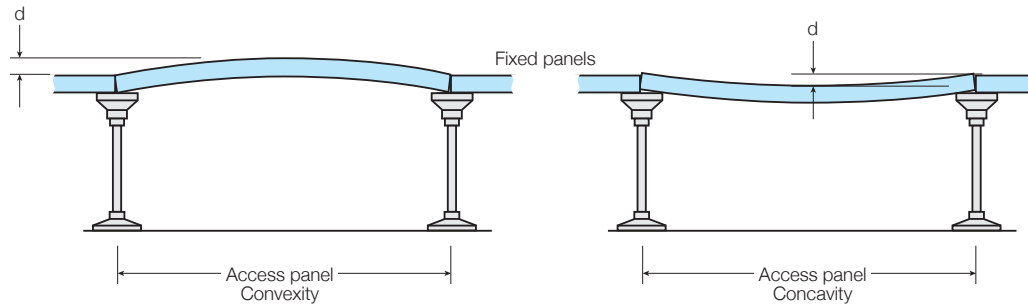

Figure 16

T23.00 | Panel Levels & Panel Flatness: Fixed Panels Only

T23.01

Test specimen

The specimen shall be the 2400 mm x 2400 mm area of flooring described in Clause T21.00.

P3.08
P3.09

T23.02

Mounting for test

As described in Clause T21.00.

T23.03

Method of test

Before the application of any test loads to the specimen, the difference in height of any adjacent panels shall be measured. The measurements shall be taken at any point which the test authority considers will give the maximum level difference. Measurements shall be determined using a bridge and dial gauge to an accuracy of 0.01 mm. See Figure 17.

Before the application of any test loads to the specimen, the panel flatness (convexity and/or concavity) shall be measured. The measurements shall be taken over at least five 600 mm square modules selected at random by the test authority. The measurements shall be made across two diagonals and at four points equidistant across the module parallel to two edges at right angles.

The measurements shall be determined using a bridge and dial gauge to an accuracy of 0.01 mm. See Figure 18.

T23.04

Test report

The test report shall contain the following information:

- The environmental conditions at the time of measurement.
- The maximum difference in height between adjacent panels.
- The specified limit of 0.75 mm max.
- The maximum concavity or convexity measured.
- The specified limit of 0.75mm max.

T23.00 | Panel Levels & Panel Flatness: Fixed Panels Only

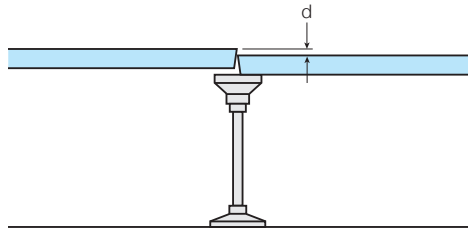

Figure 17 Difference in height between adjacent panels

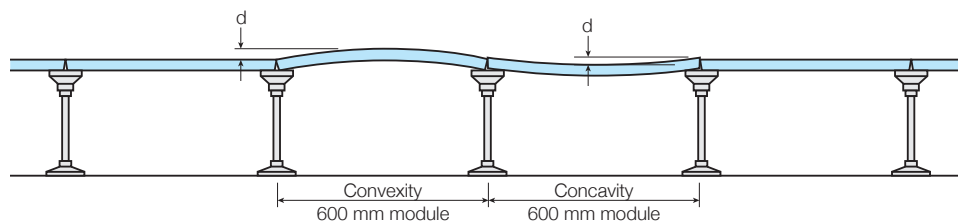

Figure 18

T24.00 | Twist: Removable Access Panels Only

T24.01

Test specimen

All of the access panels used for Test T22.00.

P3.09
P5.02

T24.02

Mounting for test

The panels shall be tested on a plane reference surface.

T24.03

Method of test

The top surface of each panel shall be brought into contact with the plane reference surface or reference points on a plane so that three out of the four corners of the panel are in contact with the reference surface or points. The distance of the fourth corner from the reference surface or point shall be measured with a suitable instrument to an accuracy of 0.01 mm. See Figure 19.

T24.04

Test report

The test report shall contain the following information:

- The size of the access panel.
- The environmental conditions at the time of measurement.
- The maximum twist 'd' Figure 19 of each panel.
- The specified limit of 1mm max over 600 mm module.

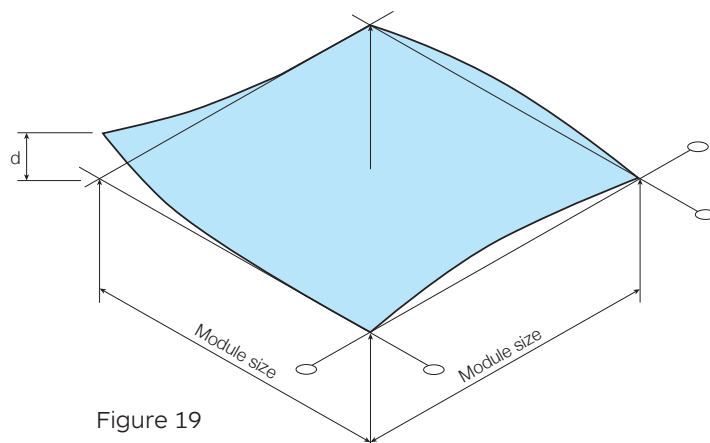

Figure 19

T25.00 | Panel Squareness: Removable Access Panels Only

T25.01

Test specimen

All of the access panels used for Test T22.00.

P3.10

T25.02

Mounting for test

None required.

T25.03

Method of test

The two diagonals shall be measured to an accuracy of 0.5 mm. See Figure 20.

T25.04

Test report

The test report shall contain the following information:

- a. The size of the access panel.
- b. The environmental conditions at the time of measurement.
- c. The diagonal measurements of each panel.
- d. The difference between the two diagonal measurements of each panel.
- e. The difference expressed as a percentage of the shorter diagonal for each panel.
- f. The specified limit of 0.06% max.

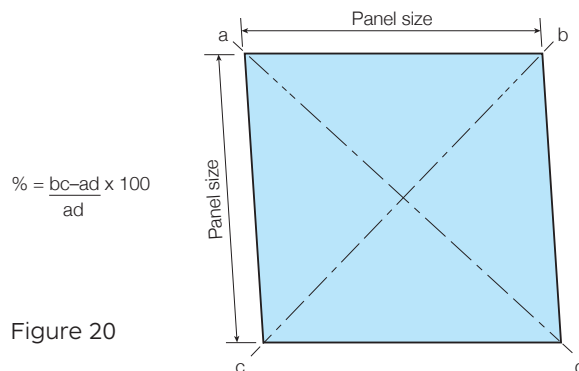

Figure 20

T26.00 | Pull of Strength of Panel Edge Strip: If Applicable

T26.01

Test specimen

One of the access panels used for Test T22.00 if these panels have edge stripping.

P3.12

T26.02

Mounting for test

The panel shall be firmly mounted with the face vertical and each edge, in turn, horizontal.

T26.03

Method of test

The end of each edge strip shall be peeled off for a distance of 75 mm with the panel mounted as above and the strip to be tested on the lower horizontal edge. A weight of 0.5 kg (giving a force of 5 N) shall be attached to the strip and held for 5 minutes. The three other edges shall be tested in a similar manner. See Figure 21.

T26.00 | Pull of Strength of Panel Edge Strip: If Applicable

T26.04

Test report

The test report shall include the following information:

- Description of the edge strip.
- Type of fixing.
- The environmental conditions at the time of test.
- A statement that the strip DID or DID NOT move during or after the application of force at each edge.
- The specified limit - "No movement".

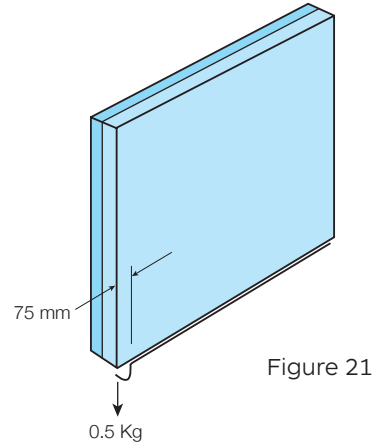

Figure 21

T27.00 | Test for Free Play in Pedestal

T27.01

Test specimen

Two pedestals which shall be the maximum height of the type of system submitted.

P4.07

T27.02

Mounting for test

The pedestals shall be firmly fixed to a horizontal surface.

T27.03

Method of test

The free play in the pedestal shall be measured in a manner similar to that shown in Figure 22.

A horizontal load of 5 N shall be applied to the pedestal head, this load shall then be applied in the opposite direction and the total movement at the head, if any, shall be measured to an accuracy of 0.01 mm. See Figure 22.

T27.04

Test report

The test report shall include the following information:

- A description of the pedestal including details of any material used to restrict movement, e.g. epoxy resin in threads or joints.
- Height of the pedestal (h).
- Total movement.
- Total movement per 100 mm height.
- The specified limit of 1 mm per 100 mm height.

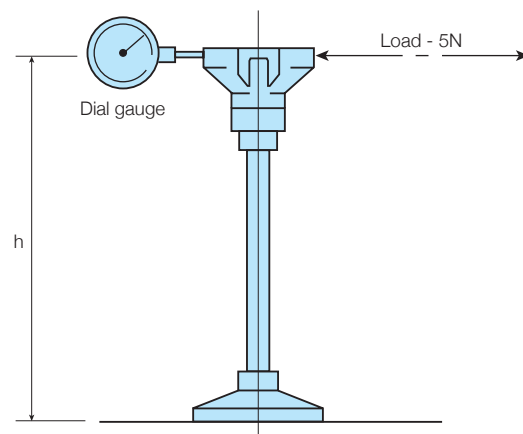

Figure 22

T28.00 | Air Leakage Rate

T28.01

Test specimen

The test specimen shall be an area of floor 1200 mm square with associated pedestals. The floor will contain an access panel and shall be generally of the form shown in Figure 23. P3.14

T28.02

Mounting for test

The 1200 mm square floor shall be set into a suitable airtight box as shown in Figure 23. The gap between the periphery of the panels and the box shall be sealed.

T28.03

Method of test

A fan shall be connected via a suitable air flow meter to the cavity formed by the floor specimen in the box. The pressure exerted in the cavity shall be measured by means of a manometer and adjusted to the required level. The rate of flow at the required pressure level shall be measured over a period of at least 5 minutes or longer if necessary, to determine the volume flow of air to within 2%. Two tests shall be carried out, the first with the access panel joints sealed and the second with the access panel joints unsealed and the remainder of the joints sealed.

T28.04

Test report

The test report shall include the following information.

- a. A description of the joint between panels.
- b. The environmental conditions at the time of test.
- c. The air leakage rate measured and calculated as litres per minute per metre length of joint at the following mm wg pressures: 2.5, 5, 7.5, 10, 12.5, 15, 17.5, 20, 22.5 and 25 for the fixed panel joints and for the access panel.
- d. A statement that this test is indicative only.

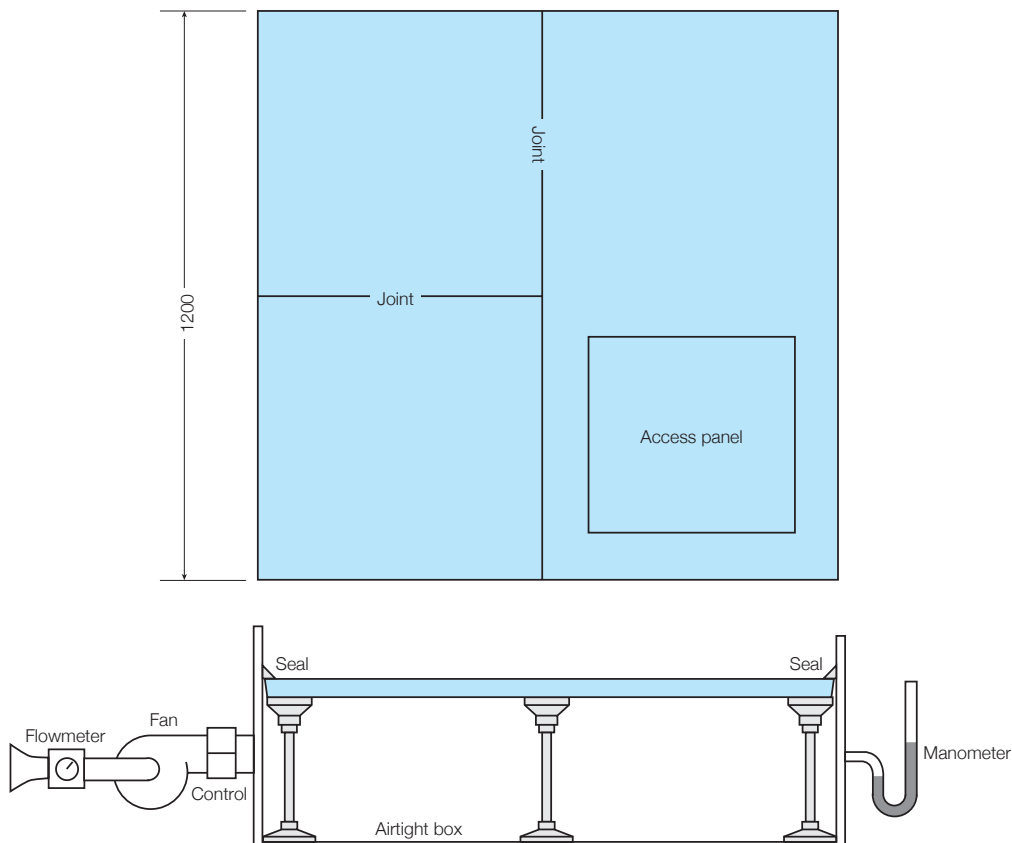

Figure 23

T29.00 | 300 mm Square Loading Test

T29.01

Test specimen

The specimen shall be the 2400 mm x 2400 mm area of flooring described in Clause T21.00.

P4.01

P4.02

T29.02

Mounting for test

As described in Clause T21.00.

The tests shall not be commenced until at least 48 hours have elapsed from the time that any adhesives used to install the specimen were first applied.

T29.03

Method of test

The indenter shall be a steel plate 300 mm square not less than 10 mm thick with corners rounded to a radius of not more than 2 mm. It shall be weighed, and the force exerted by this weight shall be deducted from the applied load.

The indenter shall be applied:

- a. To the centre of a module of the declared pedestal grid.
 - b. To the centre span of two pedestals.
 - c. To the centre span of two pedestals along a joint such that one edge of the indenter is contiguous with the edge of a panel.
 - d. To the centre span of two pedestals at the perimeter with the edge of the indenter continuous with the edge of the panel.
 - e. To the centre of an adjacent panel.
 - f. To an access panel such that the edge of the indenter is contiguous with one edge of the panel at mid span. The load shall be carried completely by the access panel and not the floor.
 - g. To the floor adjacent to an access panel such that the edge of the indenter is continuous with an edge of the access orifice at mid- span. The load shall be carried completely by the floor and not by the access panel.
- and
- h. To any other point on the specimen which the test authority may consider to be an area of weakness.

Note: Suggested areas for the above tests are shown as □ on Figure 15. A bedding-in load consisting of the test load shall be applied and maintained for a period of five minutes via the indenter and then released. An unloaded period of 5 minutes ± 1 minute shall elapse before the commencement of the actual test and the zero-load deflection reading is taken.

The particular static load specified in Clause P4.01 shall be applied and maintained for 24 hours at the centre of the indenter by means of a suitable test apparatus similar to that shown in Figure 24.

The deflections produced by this load shall be measured to an accuracy of 0.01 mm at:

Under the floor at the centre of the indent or at areas a and e referred to above;

or

Under the floor at the centre of edge of the indenter contiguous with any joint or edge of a panel,

- i. The instant the load is applied.*
- ii. 23 hours after the load was first applied.*
- iii. 24 hours after the load was first applied and before the removal of the load.*
- iv. 2 hours after the load was removed.*

Two hours after removal of the load, the top surface of the specimen shall be examined, and any indentation caused by the loaded indenter shall be measured. The specimen shall also be examined for any other permanent deformation.

T29.00 | 300 mm Square Loading Test

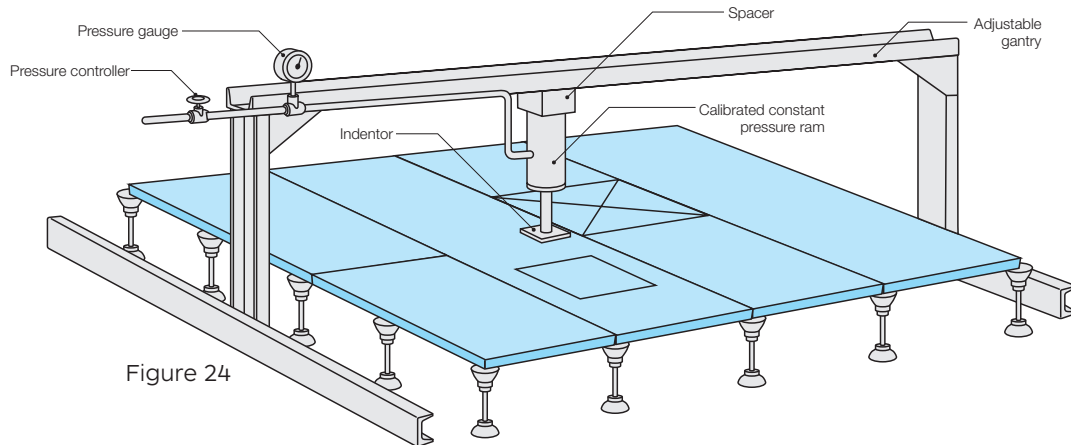

Figure 24

T29.04 Test report

The test report shall include the following information:

- a. The structural grade of the system - Light or Medium and the applicable test load.
- b. The average environmental conditions over the period of each test.
- c. Deflection in the system after 23 hours of loading.
- d. Deflection in the system after 24 hours of loading.
- e. Maximum permitted deflection: 1/250th of the span or 2.5 mm whichever is the least.
- f. Difference between c and d (stability). Maximum 0.02 mm.
- g. Residual deflection 2 hours after load was removed. Maximum 0.5 mm.
- h. Permanent indentation of the top surface of panel. Maximum 0.15mm.
- i. Any other permanent deformation in the system.

Note: Results c to i are required for each test position.

T30.00 | 25 mm Square Point Loading Tests

T30.01 Test specimen

The specimen shall be the 2400 mm x 2400 mm area of flooring described in Clause T21.00.

P4.01
P4.02

T30.02 Mounting for test

As described in Clause T21.00.

The tests shall not be commenced until at least 48 hours have elapsed from the time that any adhesives used to install the specimen were first applied.

T30.03 Method of test

The indenter shall be a 25 mm steel cube the corners of which shall be rounded off to a radius of not more than 2mm.

The indenter shall be applied:

- a. To the centre of a module of the declared pedestal grid.
- b. To the centre span of two pedestals.
- c. To the centre span of two pedestals along a joint such that one edge of the indenter is contiguous with the edge of a panel.

T30.00 | 25 mm Square Point Loading Tests

- d. To the centre span of two pedestals at the perimeter with one edge of the indenter contiguous with the edge of the panel.
 - e. To the centre of an access panel.
 - f. To an access panel such that the edge of the indenter is contiguous with one edge of the panel at mid span. The load shall be carried completely by the access panel and not the floor.
 - g. To the floor adjacent to an access panel such that the edge of the indenter is contiguous with an edge of the access orifice at mid span. The load shall be carried completely by the floor and not by the access panel.
- and
- h. To any other point on the specimen which the test authority may consider to be a point of weakness.

Wherever possible, the foregoing areas shall not coincide with those selected for the 300 mm square loading tests.

Note: Suggested areas for the above point loading tests are shown thus ■ on Figure 15. A bedding-in load consisting of the test load shall be applied and maintained for a period of five minutes via the indenter and then released. An unloaded period of 5 minutes ± 1 minute shall elapse before the commencement of the actual test and the zero load deflection reading is taken.

The particular static load specified in Clause P4.01 shall be applied and maintained for 24 hours at the centre of the indenter by means of a suitable test apparatus similar to that shown in Figure 24.

The deflections produced by this load shall be measured at the centre of the indenter position on the panel to an accuracy of 0.01 mm at:

- i. The instant the load is applied.
- ii. 23 hours after the load was first applied.
- iii. 24 hours after the load was first applied and before the removal of the load.
- iv. 2 hours after the load was removed.

Where deflection readings coincide with profile changes to the underside of the panel, then the average of two adjacent readings shall be recorded. These readings shall be taken directly below the indenter position, to record deflections each side of the profile change.

When the profile change to the panel soffit extends beyond the area of the indenter position then the deflection readings shall be obtained from the top surface of the panel immediately adjacent to the indenter.

The average of the two readings shall be recorded as the deflection produced, See Figure 6a.

Two hours after removal of the load, the top surface of the specimen shall be examined, and any indentation caused by the loaded indenter shall be measured. The specimen shall also be examined for any other permanent deformation.

T30.04 Test report

The test report shall include the following information:

- a. The structural grade of the system and the applicable test load.
- b. The average environmental conditions over the period of each test.
- c. Deflection in the system after 23 hours of loading.
- d. Deflection in the system after 24 hours of loading.
- e. Maximum permitted deflection: 1/250th of the span or 2.5 mm whichever is the least.
- f. Difference between c and d (stability). Maximum 0.02 mm.
- g. Residual deflection 2 hours after load was removed. Maximum 0.5 mm.
- h. Permanent indentation of the top surface of panel. Maximum 0.15 mm.
- i. Any other permanent deformation in the system.

Note: Results c to i are required for each test position.

T31.00 | Uniformly Distributed Load Test

T31.01

Test specimen

The specimen shall be the 2400 mm x 2400 mm area of flooring described in Clause T21.00.

P4.01

P4.02

T31.02

Mounting for test

As described in Clause T21.00.

The tests shall not be commenced until at least 48 hours have elapsed from the time that any adhesives used to install the specimen were first applied.

T31.03

Method of test

The particular uniformly distributed static load specified in Clause P4.01 shall be applied to two 1200 mm x 1200 mm quadrants of the specimen, one of which shall include an access panel, by means of rams and spreader plates to the top surface. The spreader plates shall be as detailed in Figure 25. The spreader plates shall be weighed, and the force exerted by this weight shall be deducted from the applied load.

A bedding-in load consisting of the test load shall be applied and maintained for a period of five minutes via the spreader plates and then released. An unloaded period of 5 minutes \pm 1 minute shall elapse before the commencement of the actual test and the zero deflection readings are taken. The particular uniform distributed static load specified in Clause P4.01 shall be applied and maintained for 24 hours by means of suitable calibrated rams applied to the spreader plates.

Deflections produced by the load shall be measured to an accuracy of 0.01mm under the floor at the following positions:

- a. At the centre of a module.
 - b. At the centre span of two pedestals.
 - c. At the centre span of two pedestals along a joint.
 - d. At the centre span of two pedestals at the perimeter edge.
 - e. At the centre of an access panel.
 - f. At the centre of an edge of the access panel.
 - g. At the centre of an edge of the access orifice.
- and
- h. At any point which the test authority may consider to be a point of weakness, at:
 - i. The instant the load was applied.
 - ii. 23 hours after the load was first applied.
 - iii. 24 hours after the load was first applied and before the removal of the load.
 - iv. 2 hours after the load was removed.

T31.04

Test report

The test report shall include the following information:

- a. The structural grade of the system and the applicable test load.
- b. The average environmental conditions over the period of the test.
- c. Deflections in the system after 23 hours of loading.
- d. Deflections in the system after 24 hours of loading.
- e. Maximum permitted deflection: 1/250th of the span or 2.5 mm whichever is the least.
- f. Difference between c and d (stability). Maximum 0.02 mm.
- g. Residual deflection 2 hours after load was removed. Maximum 0.5 mm.
- h. Any other permanent deformation in the system.

Note: Results c to h are required for each measurement position.

T32.00 | Soft Body Impact Test

T32.01 Test specimen

P4.04

The specimen shall be the 2400 mm x 2400 mm area of flooring described in Clause T21.00. A spare access panel which has not been subjected to any other tests shall be installed in one access orifice.

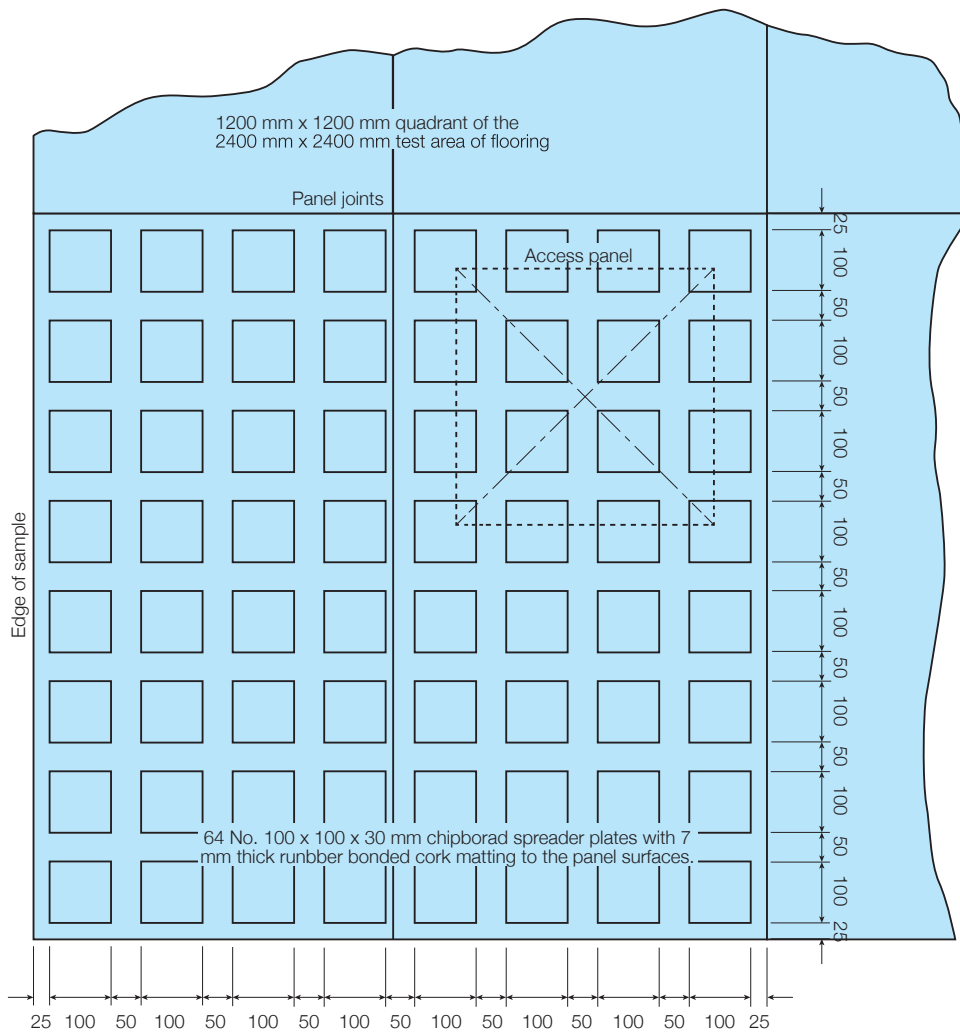

Method of load application shall be similar to that detailed for a 600 x 600 mm full access panel. See Fig 7a.

Figure 25 Detail of UDL Spreader Plates

T32.02 Mounting for test

As described in Clause T21.00.

The tests shall not be commenced until at least 48 hours have elapsed from the time that any adhesives used to install the specimen were first applied.

T32.00 | Soft Body Impact Test

T32.03

Method of test

A canvas bag 600 mm high with a 300 mm diameter base containing dry sand to a mass of 40 kg. The bag shall be dropped on to the specimen from a height of 1 metre at the following positions with the whole of the base coming into contact with respective panel area:

- a. On to the centre of a module.
- b. On to the centre span of two pedestals.
- c. On to the centre span of two pedestals along a joint.
- d. On to the centre span of two pedestals at the perimeter edge.
- e. On to the centre of the access panel.
- f. On to the centre of edge of the access panel.
- g. On to the centre of edge of the access orifice.
- h. On to any other area which the test authority may consider to be a point of weakness.

Wherever possible, the foregoing areas shall not coincide with those selected for static loading tests.

The specimen should not collapse on or after any of the impacts, but careful observation shall be made to determine whether any damage has occurred. See Figure 26.

T32.04

Test report

The test report shall include the following information:

- a. The pedestal grid size and the access panel size.
- b. The environmental conditions at the time of the test.
- c. A statement that the system DID or DID NOT collapse.
- d. A report of the collapse characteristic, if applicable or of any other deformation.

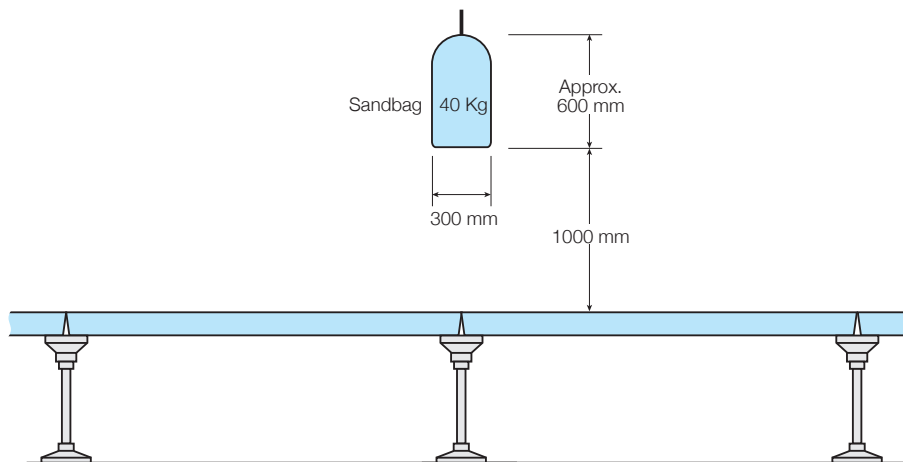

Figure 26

T33.00 | Hard Body Impact Test

T33.01

Test specimen

The specimen shall be the 2400 x 2400 mm area of flooring described in Clause T21.00. A spare access panel which has not been subjected to any other tests shall be installed in one access orifice.

P4.04

T33.02

Mounting for test

As described in Clause T21.00.

The tests shall not be commenced until at least 48 hours have elapsed from the time that any adhesives used to install the specimen were first applied.

T33.03

Method of test

A steel indenter weighing 4.5 kg with a 50 mm hemispherical end shall be dropped on to the specimen from a height of 600 mm guided within a suitably sized tube at the following positions:

- a. On to the centre of a module.
- b. On to the centre span of two pedestals.
- c. On to the centre span of two pedestals along a joint.
- d. On to the centre span of two pedestals at the perimeter.
- e. On the centre of the access panel.
- f. On to a centre of edge of the access panel.
- g. On to a centre of edge of the access orifice.
- h. On to any other area which the test authority may consider to be a point of weakness.

Wherever possible, the foregoing areas shall not coincide with those selected for static loading tests and soft body impact tests.

The specimen should not collapse on or after any of the impacts, but careful observations shall be made to determine whether any damage has occurred. See Figure 27.

T33.04

Test report

The test report shall include the following information:

- a. The pedestal grid size and the access panel size.
- b. The environmental conditions at the time of the test.
- c. A statement that the system DID or DID NOT collapse.
- d. A report of the collapse characteristic, if applicable, or of any other deformation.

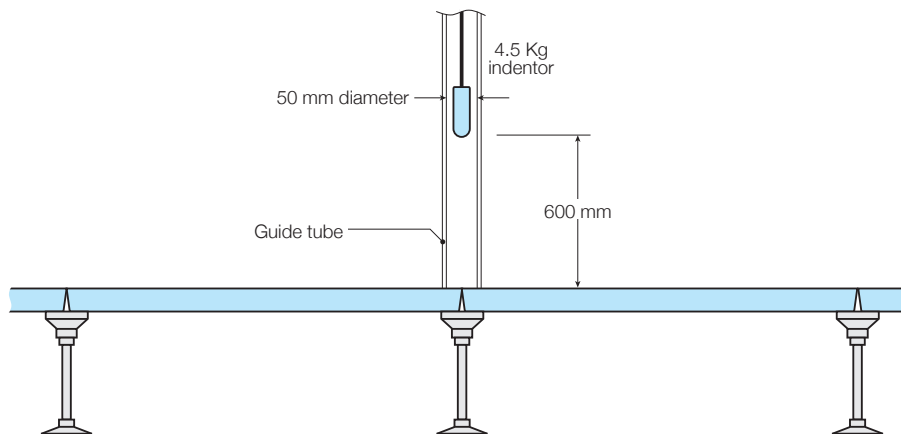

Figure 27

T34.00 | Pedestrian Dynamic Load Test

T34.01

Test specimen

The specimen shall be the 2400 mm x 2400 mm area of flooring described in Clause T21.00.

P4.05

T34.02

Mounting for test

As described in Clause T21.00.

The tests shall not be commenced until at least 48 hours have elapsed from the time that any adhesives used to install the specimen were first applied.

T34.03

Method of test

An indenter consisting of a steel plate 100 mm diameter and not less than 10 mm thick on top of a 100 mm diameter x 3 mm thick piece of vulcanised rubber of 70° to 90° Shore A Hardness shall be actuated by a mechanism capable of exerting vertical and horizontal forces on the specimen.

After completion of the point load tests detailed in Clause T30.00 the specimen shall be subjected at:

- i. Test point a. - the centre of a fixed panel module and
- ii. Test point e. - the centre of an access panel to 250,000 loading cycles at each area through the indenter.

Each cycle shall consist of the following:

- | | |
|-----------|---|
| 0 seconds | Apply a downward vertical force of 1 kN. |
| 1 second | Apply a horizontal force of 170 N in one longitudinal direction followed by the same force in the opposite direction. |
| 2 seconds | Remove the downward vertical force. |
| 3 seconds | Apply a downward vertical force of 1 kN and so on. |

The specimen shall be allowed to bed in by the application of 100 cycles. The horizontal movement and the vertical deflection shall be measured over the next 10 cycles.

After 249,990 cycles the horizontal movement and the vertical deflection shall be measured over the final 10 cycles.

All measurements shall be to an accuracy of 0.01 mm.

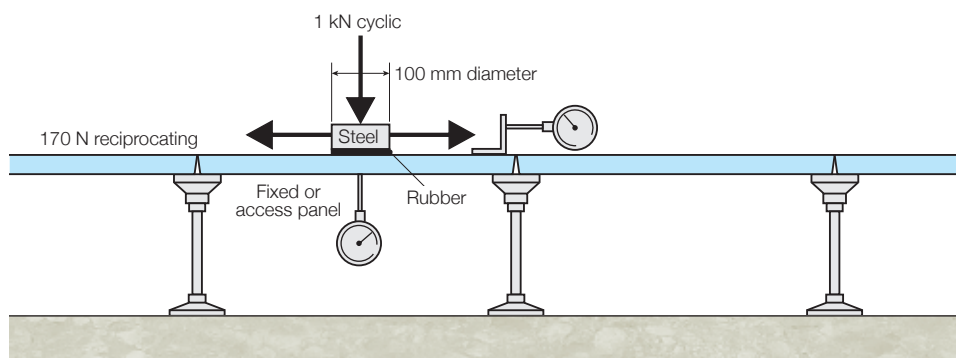

Figure 28

T34.04

Further tests on specimen

After completion of the dynamic load tests, the positions tested shall be subjected to the particular point load test detailed in Clause T30.00. The deflections produced shall be within the requirements detailed in Clause P4.02.

T34.00 | Pedestrian Dynamic Load Test

T34.05

Test report

The test shall include the following information:

- a. The structural grade of the system and the test load for the point load test.
- b. The pedestal grid size, access panel size and the height of the system.
- c. The average environmental conditions over the period of the test.
- d. Mean horizontal movement over the first 10 cycles (after the 100 bedding cycles). Maximum 1.5mm.
- e. Mean vertical deflection over the first 10 cycles (after the 100 bedding cycles). Maximum 1mm.
- f. Mean horizontal movement over the last 10 cycles. Maximum 1.5 mm.
- g. Mean vertical deflection over the last 10 cycles. Maximum 1 mm.
- h. Increase in horizontal movement between d and f. Maximum 0.5 mm.
- i. Increase in vertical deflection between e and g. Maximum 0.33 mm.
- j. All deflection measurements required by Clause T30.00.
- k. Report of any wear, de-lamination, cracking or any other deterioration.

T35.00 | Pedestal Strength - Horizontal Load

T35.01

Test specimens

The test specimen where pedestals are fixed permanently to the underside of the panels and to the sub floor shall be the 2400 mm x 2400 mm area of flooring described in Clause T21.00. Two pedestals shall be selected by the test authority for the test.

P4.07

T35.02

Mounting for test

As described in Clause T21.00.

The tests shall not be commenced until at least 48 hours have elapsed from the time that any adhesives used to install the specimen were first applied.

T35.03

Method test

A steady horizontal moment of 90 Nm up to a maximum applied load of 50 kg shall be applied at the half height of a pedestal for 5 minutes and then released. The load shall be applied to each of the selected pedestals in turn. After removal of the force, permanent deformation, if any, shall be measured at the half height of the pedestal to an accuracy of 0.01 mm.

The specimen shall be inspected for any sign of detachment of the pedestal head from the underside of the panels and of any failure of the bond between the pedestal base and the substrate.

The method of attachment and application of the force shall be at the discretion of the testing authority. See Figure 29.

T35.04

Test report

The test report shall include the following information:

- a. Height of the pedestals.
- b. Load applied in kilograms. Maximum 50 kg.
- c. Permanent deformation.
- d. Permanent deformation per 100 mm in height.
- e. Report of any detachment from the underside of the panels or of any failure of the bond between the pedestal base and the substrate.

T35.00 | Pedestal Strength - Horizontal Load

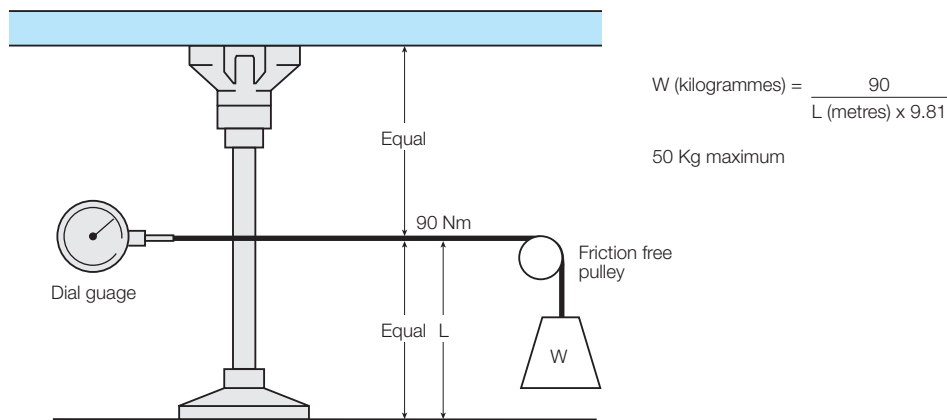

Figure 29

T35.05

Tests on pedestal not fixed to the underside of panels

Where pedestals are not permanently fixed to the underside of panels, two specimen pedestals of the relevant height shall be submitted to the test detailed in Clause T15.00. All information required by Clause T15.04 shall be included in the test report.

T36.00 | Pedestal Strength - Vertical Load

T36.01

Test specimens

The specimen shall be the 2400mm x 2400mm area of flooring described in Clause T21.00 and a spare access panel.

P4.07

T36.02

Mounting for test

As described in Clause T21.00.

The tests shall not be commenced until at least 48 hours have elapsed from the time that any adhesives used to install the specimen were first applied.

T36.03

Method of test

Test a. At the centre of the pedestal head. See Figure 30. Two pedestals shall be subjected to this test. The specified load of 10.8 kN for Light grade or 18 kN for all other grades shall be applied and maintained through a 50mm x 50mm indenter located over the centre of the selected pedestal via the fixed and removable access panels for a period of five minutes and then removed. During the period of loading the pedestal should not collapse.

Test b. Over one quadrant of the pedestal head. See Figure 30. Two pedestals at the corner of an access panel shall be subjected to this test. The specified load of 8.1 kN for Light grade, 9kN for Medium grade and 13.5 kN Heavy and Extra Heavy Grade shall be applied and maintained through a 50mm x 50mm indenter located over a corner of the removable access panel through to the quadrant of the pedestal head for a period of five minutes and then removed. During the period of loading the pedestal should not collapse.

T36.04

Test report

The test report shall include the following information:

- a. The structural grade of the system and the test loads.
- b. A statement that the pedestals DID or DID NOT collapse.
- c. A report of the collapse characteristic if applicable or of any other deformation.

METHODS OF TEST FOR PARTIAL ACCESS FLOOR SYSTEMS

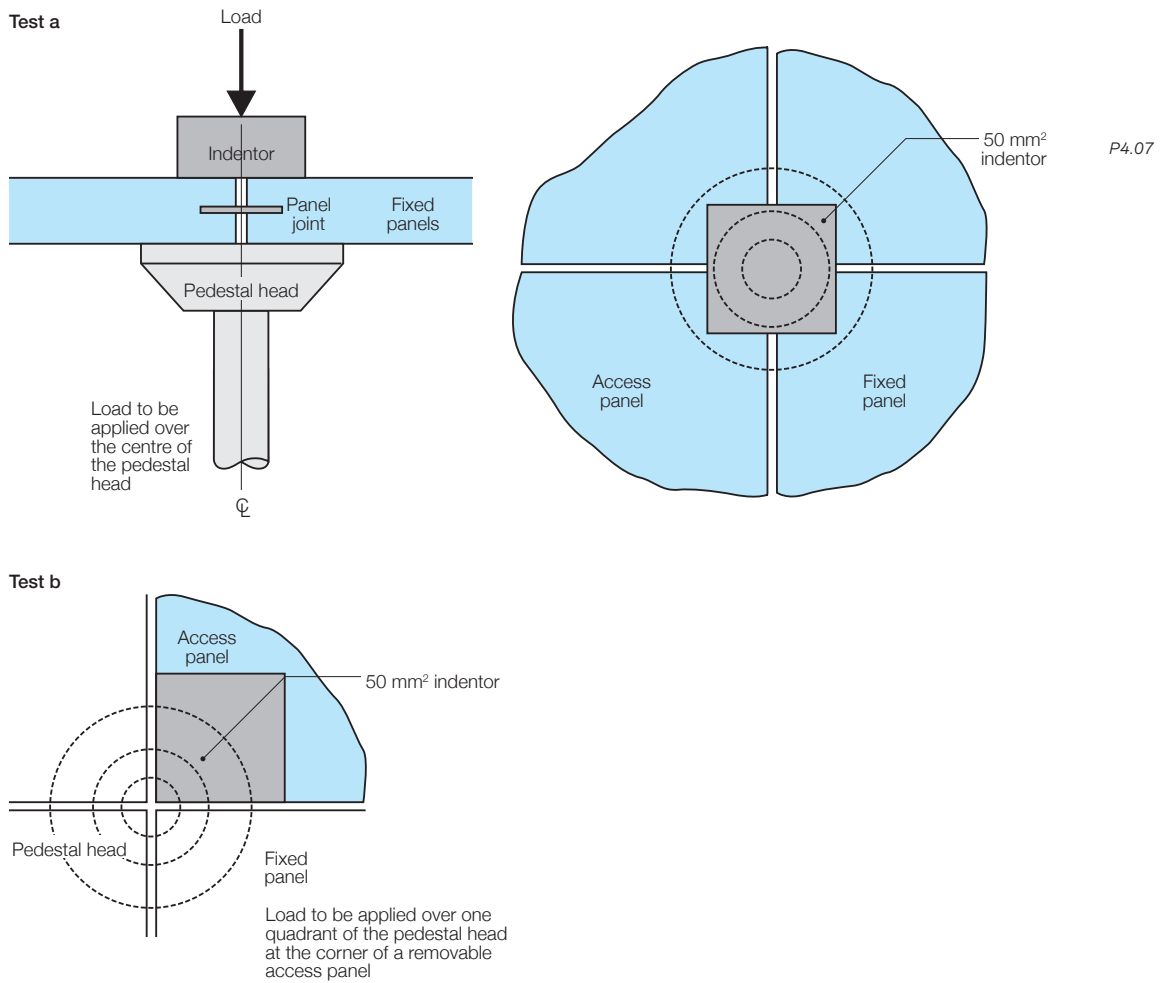

Figure 30

T37.00 | Effect of Temperature

T37.01

Test specimens

One removable access panel without floor covering and one 600mm x 600mm module cut from a fixed type panel.

T37.02

Mounting for test

The panels shall be conditioned unmounted. The Access panel shall be installed in the access orifice in the 2400mm x 2400mm area of flooring for the measurement and loading part of the test.

T37.03

Method of test

The concavity, convexity, twist and squareness of the access panel shall be measured as detailed for tests T22.00, T24.00 and T25.00. The concavity, convexity and twist of the 600 mm x 600 mm module cut from a fixed panel shall be measured in a similar manner to that detailed for tests T22.00 and T24.00. The specimen shall be mounted on 25 mm square blocks for test T22.00. The panels shall be placed flat with their edges supported and separated from their neighbour by at least 25 mm in an air circulating oven/refrigerator which shall be capable of maintaining the specified temperature to within $\pm 1^\circ\text{C}$ dry bulb. The panels shall be conditioned at 5°C dry bulb for 14 days (336 hours) continuously after which any change in concavity, convexity and twist shall be ascertained by measurements detailed above.

T37.00 | Effect of Temperature

The panels shall then be conditioned at 30 °C dry bulb for 14 days (336 hours) continuously, after which any change in concavity, convexity, twist and access panel squareness shall be ascertained by measurement as detailed above. After each conditioning period the panels shall be examined for any de-lamination of materials or components.

Twenty four hours± 1 hour after completion of the foregoing conditioning, the access panel only shall be subjected to the 25 mm x 25 mm point load test as detailed for test T30.00 on the position which produced the greatest deflection in test T30.00. This may necessitate the testing of two adjacent centre of edges.

T37.04 Test report

The test report shall include the following information:

1. The access panel:
 - a) Dimensional deviations (Tests T22, T24 and T25) before conditioning.
 - b) Dimensional deviations (Tests T22, T24 and T25) after 14 days @5°C.
 - c) Dimensional deviations (Tests T22, T24 and T25) after 14 days @30 °C.
 - d) Dimensional changes (Tests T22, T24 and T25) after each conditioning period.
 - e) Report of any de-lamination of materials or components.
 - f) Any other deterioration of the panel.
 - g) All information required by test T30.00.
2. The 600 mm x 600 mm module cut from a fixed panel:
 - a) Dimensional changes (Tests T22 and T24) after each conditioning period.
 - b) Report of any de-lamination of materials or components.
 - c) Any other deterioration of the specimen.
 - d) A statement that the test results of this panel are indicative only.

T38.00 | Effect of Humidity

T38.01 Test specimens

One removable access panel without floor covering and one 600 mm x 600 mm module cut from a fixed type panel.

P5.02

T38.02 Mounting for test

The panels shall be conditioned unmounted. The access panel shall be installed in the access orifice in the 2400 mm x 2400 mm area of flooring for the measurement and loading part of the test.

T38.03 Method of test

The concavity, convexity, twist and squareness of the access panel shall be measured as detailed for tests T22.00, T24.00 and T25.00. The concavity, convexity and twist of the 600 mm x 600 mm module cut from a fixed type panel shall be measured in a similar manner to that detailed for tests T22.00 and T24.00. The specimen shall be mounted on 25 mm square blocks for test T22.00. The panels shall be placed flat with their edges supported and separated from their neighbour by at least 25 mm in a conditioning cabinet capable of maintaining the specified temperature to within ± 1°C and a humidity sensitivity of +/- 2.0% R.H. The panels shall be conditioned at 23°C 25% RH for 14 days (336 hours) continuously, after which any change in concavity, convexity and twist shall be ascertained by measurement as detailed above.

T38.00 | Effect of Humidity

The panels shall then be conditioned at 23 °C 75% RH for 14 days (336) hours) continuously, after which any change in concavity, convexity, twist and access panel squareness shall be ascertained by measurement as detailed above. After each conditioning period the panels shall be examined for any de-lamination of materials or components.

Twenty four hours± 1 hour after completion of the foregoing conditioning the access panels only shall be subjected to the 25 mm x 25 mm point load test as detailed for test T30.00 on the position which produced the greatest deflection in test T30.00. This may necessitate the testing of two adjacent centre of edges.

T38.04 Test report

The test report shall include the following information:

1. The access panel:
 - a) Dimensional deviations (Tests T22, T24 and T25) before conditioning.
 - b) Dimensional deviations (Tests T22, T24 and T25) after 14 days @ 23 °C 25% RH.
 - c) Dimensional deviations (Tests T22, T24 and T25) after 14 days @ 23 °C 75% RH.
 - d) Dimensional changes (Tests T22, T24 and T25) after each conditioning period.
 - e) Report of any de-lamination of materials or components.
 - f) Any other deterioration of the panel.
 - g) All information required by test T30.00.
2. The 600 mm x 600 mm module cut from a fixed panel.
 - a) Dimensional changes (Tests T22 and T24) after each conditioning period.
 - b) Report of any de-lamination of materials or components.
 - c) Any other deterioration of the specimen.
 - d) A statement that the test results of this panel are indicative only.

T39.00 | Safety Factor Load Tests

T39.01 Test specimens

P4.03

The specimen shall be the 2400 mm x 2400 mm area of flooring described in Clause T21.00. The pedestals which were subjected to loading during tests T35.00 (horizontal load) and T36.00 (vertical load) shall be replaced before the commencement of the safety factor load tests. The access panels which were used for the static load tests shall be used for the safety factor load tests.

T39.02 Mounting for test

As described in Clause T21.00. The tests shall not be commenced until at least 48 hours have elapsed from the time that any adhesives used to fix the replaced pedestals were first applied.

T39.03 Method of test

The safety factor load tests shall not be carried out until tests T22.00, T23.00, T29.00, T30.00, T31.00, T32.00, T33.00, T34.00, T35.00, T36.00, T37.00 and T38.00 have been completed using the 2400 mm x 2400 mm area of flooring.

Using the particular indentors on the positions specified for tests T29.00 and T30.00 and the spreader plates and locations specified for test T31.00, a load equal to three times that specified for each particular test shall be applied and maintained for a period of five minutes and then removed. During any period of loading, the system should not collapse.

T39.00 | Safety Factor Load Tests

T39.04

Test report

The test report shall include the following information:

- a. The structural grade of the system and the test loads.
- b. The environmental conditions at the time of each test.
- c. A statement that the system DID or DID NOT collapse at any of the areas tested.
- d. A report of the collapse characteristic if applicable, or of any other deformation.

T40.00 | Determination of Surface Spread of Flame & Index of Performance (Fire)

T40.01

Test specimen

The specimens for the Surface Spread of Flame test shall comprise six representative full-length panel sections 900mm long x 230mm wide cut from fixed type panels and six full length panel sections up to 900mm long x 230mm wide cut from a typical access panel if the construction differs from the fixed panels. The specimens for the Index of Performance tests shall comprise six representative panel sections 228mm x 228mm cut from fixed type panel sections and six 228mm x 228mm sections cut from typical access panels if the construction differs from the fixed panels. All specimens shall be of the normal panel thickness and all materials, including adhesives, core material and protective finishes shall be exactly as used in production. The attachment of any cladding to the core material shall simulate, as nearly as possible, the final installation condition, e.g. if the cladding is kept in contact with the core material by the pedestals, then it shall be permissible to use small mechanical fixings at each corner only. If the cladding is not held in place by the pedestals, then there shall be no extra mechanical fixings allowed.

P6.02

T40.02

Method of test

The tests shall be performed on the void side of the specimens only, exactly in accordance with the methods specified in BS476: Part 6: Index of Performance and BS476: Part 7: Spread of Flame.

T40.03

Test report

The results shall be reported as required by BS476: Part 6: and BS476: Part 7. In addition, any detachment of the cladding from the core material shall be reported.

T41.00 | Small Scale Fire Test

T41.01

Test specimens

P6.05

The specimen shall be sufficient panels and pedestals to install an area of flooring 1800 mm x 1800 mm. The specimen shall include all features of the normal construction applicable to the particular type of system and shall include a removable access panel. The pedestals shall be sized and set to provide a cavity height of 300 mm or set to the maximum height if the system under test has a cavity of less than 300 mm.

T41.02

Mounting for test

The panels shall be mounted on the pedestals which shall be fixed to a concrete sub floor by means of the adhesives and/or fixings proposed as the normal fixing method. If the pedestals submitted for test are less than 300 mm high, they shall be mounted and fixed to non-combustible blocks 150 mm square and of suitable height to provide a cavity height of 300 mm. The blocks shall be suitably fixed to the concrete sub floor. Any fixing adhesive used to fix the installation shall be allowed to set for a period of 48 hours \pm 5 hours before commencement of the test. The specimen shall be surrounded by an insulation block wall 450 mm high.

There shall be four ventilation ports 225 mm high x 50 mm wide on each side of the enclosure. These ports shall be protected from any external air movement by means of 450 mm high x 225 mm wide shields placed in front of the ports 25 mm from them.

See Figure 31 for arrangement.

T41.03

Test method

The source of ignition shall be a crib fire constructed from 1070g \pm 30g of 25 and 30 mm square rough sawn softwood with a moisture content of 10% to 15%. The crib shall be constructed as shown in Figure 32. It shall be fired by approximately 25 to 30g of wood wool placed underneath. It shall be placed near to a pedestal at the corner of one module and for a second test it shall be placed under the corner of the access panel. However, if, in the opinion of the test authority, any other position under the specimen is considered to be a point of weakness with regard to fire resistance, e.g. at joint intersections etc., an additional test shall be carried out at that point.

A uniformly distributed load equal to the requirement for the particular system detailed in Clause P4.01 shall be applied to the specimen as shown in Figure 31.

Instruments shall be set up to measure the deflections of the panel near to the pedestal adjacent to the crib fire, and at the mid span of the nearest panel joint to the crib fire for test 1. Deflections shall be measured at the corner of the access panel above the crib fire and at the centre of edge of the access panel nearest to the crib fire for test 2. All deflection measurements shall be to an accuracy of 0.01 mm.

The crib shall be lit and allowed to burn for a period of 30 minutes. Observations shall be made of the system within the void which shall be viewed through the ventilation ports and deflection measurements taken and recorded at 60 second intervals.

T41.04

Test report

The test report shall include the following information:

- a. The structural grade of the system and the uniformly distributed load.
- b. Fixed panel sizes, access panel size and pedestal height.
- c. The environmental conditions at the time of test.
- d. The maximum deflection at all measurement positions.
- e. A report of the visual observations including displacement of metal cladding on the underside, burning or melting of any of the constituent materials of the panels and supporting structure, any smoke or toxic fumes.
- f. Observations made on the specimen after completion of the test.

T41.00 | Small Scale Fire Test

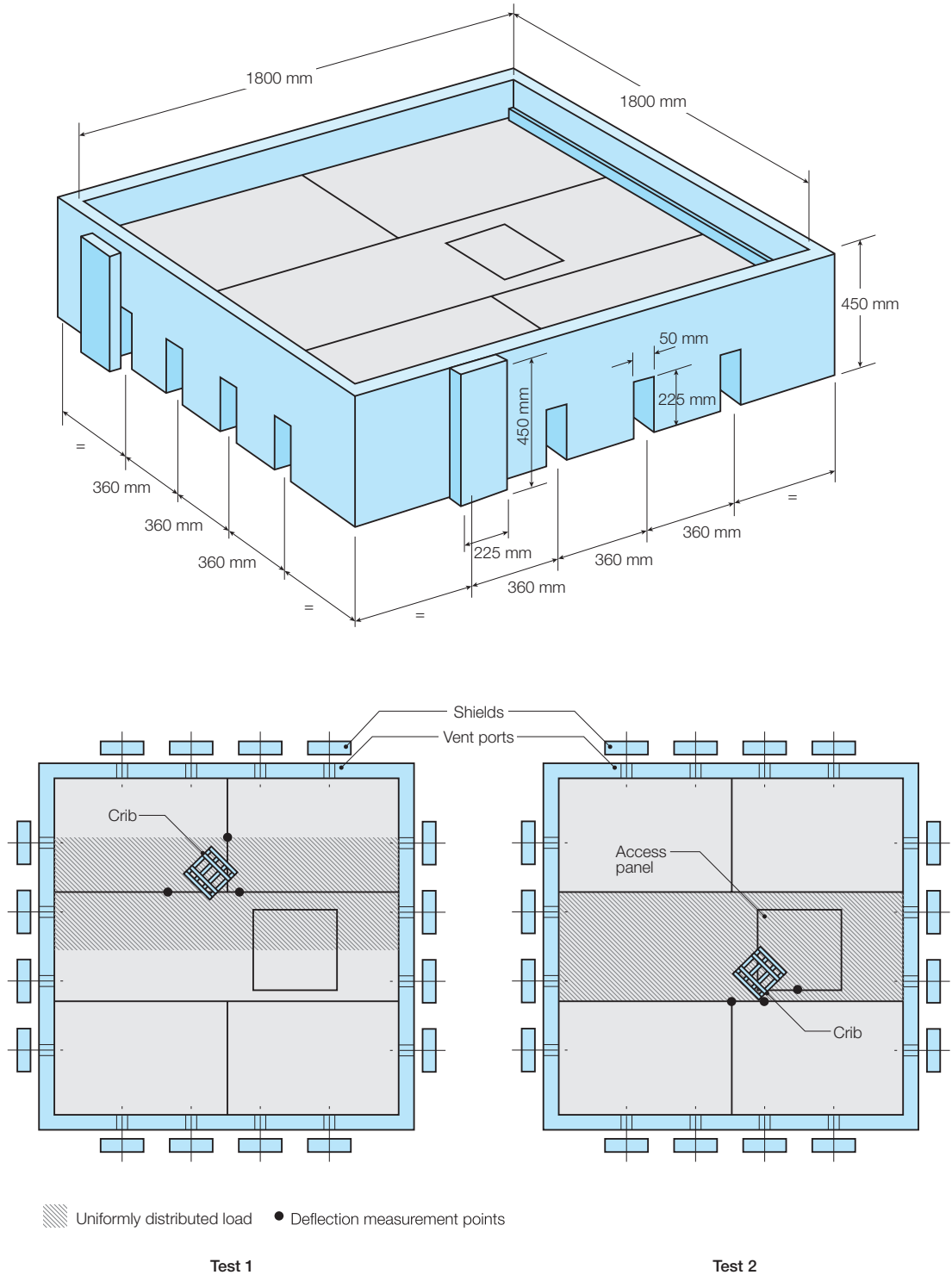

Figure 31 Arrangement of small-scale fire test (Partial Access)

T41.00 | Small Scale Fire Test

Wood sticks comprising 10 x 25 mm square and 6 x 32 mm square each 200 mm long sawn softwood with moisture content of 10 to 15%. Crib to be assembled with small quantity of PVA wood adhesive.

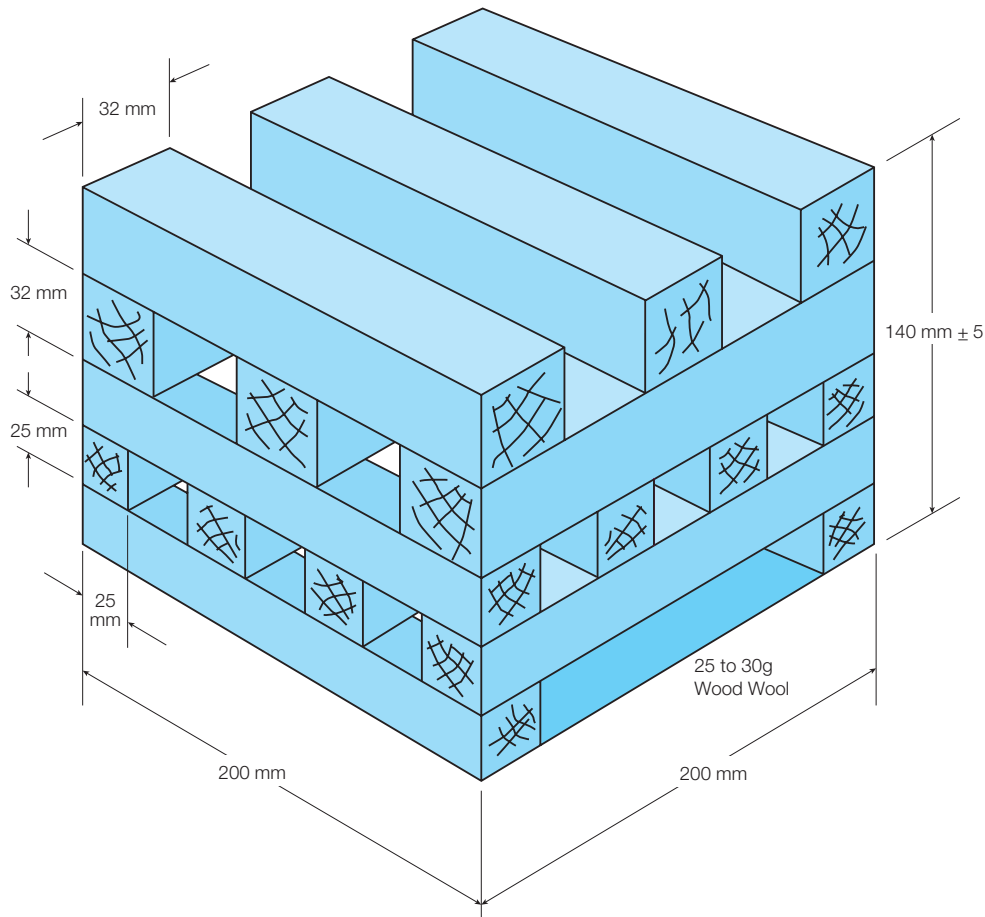

Figure 32 1070g ± 30g Fire Crib

T41a.00 | Thermal Properties

(Partial Access Systems)

T41a.01

Test specimens

The specimen, without floor covering and of components selected at random, shall be of sufficient panels and pedestals to install an area of flooring 1800mm long x 1200mm wide.

P6.08

The specimen shall include all features of the normal construction applicable to the particular type of system to simulate a central area of a typical installation and shall include two access panels which shall be generally as shown in Figure 33.

The pedestals shall be set to provide a cavity height of 300mm or set to the maximum height if the system under test has a cavity of less than 300mm.

T41a.00 | Thermal Properties

(Partial Access Systems)

T41a.01

Test specimens

The specimen, without floor covering and of components selected at random, shall be of sufficient panels and pedestals to install an area of flooring 1800mm long x 1200mm wide.

The specimen shall include all features of the normal construction applicable to the particular type of system to simulate a central area of a typical installation and shall include two access panels which shall be generally as shown in Figure 33.

The pedestals shall be set to provide a cavity height of 300mm or set to the maximum height if the system under test has a cavity of less than 300mm.

T41a.02

Mounting for test

The pedestals shall be fixed to a concrete sub floor by means of the adhesive and/or fixings proposed.

If the pedestals are less than 300mm high, then they shall be mounted and fixed to non-combustible blocks 150mm square of a suitable height to provide a cavity height of 300mm. The blocks shall be suitably fixed to the concrete sub floor.

The fixing adhesive, if any, shall be allowed to set for a period of 48 hours \pm 5 hours before commencement of the test.

The specimen shall be surrounded by an insulation block wall laid dry and to a nominal height of 415mm. There shall be six ventilation ports on each of the longer sides of the enclosure and four ventilation ports on each of the shorter sides. Each ventilation port shall be nominally 315mm high x 50mm wide. See Figure 33 for arrangement.

T41a.03

Test method

The source of ignition shall be a crib fire constructed from 1070g \pm 30g of 25 and 32mm square rough sawn softwood with a moisture content of 10% to 15%. The crib shall be constructed as shown in Figure 32. It shall be fired by 25 to 30g of wood wool placed underneath. The crib shall be placed under the floor at the centre of the mid-point of the joint.

Eighteen fixed thermocouples shall be located on the top surface of the specimen to measure the mean face temperature of the unexposed face as shown in Figure 34.

A further thermocouple (nineteenth) shall be located on the top surface of the specimen, in any position of free area which will, in the opinion of the test laboratory, record the maximum surface temperature.

Thermocouples shall be attached to the panel surface by the method defined in BS 476: Part 20. All thermocouple readings shall be included in the analysis of test results. The temperatures shall be recorded on a strip chart recorder or similar apparatus. The crib shall be lit and allowed to burn for the test period of 30 minutes.

T41a.04

Test report

The test report shall include the following information:

- a. The structural grade of the system.
- b. Fixed panel sizes, access panel sizes and pedestal height.
- c. The environmental conditions at the time of the test.
- d. The position on the top surface of the nineteenth thermocouple.
- e. Maximum top surface temperature.
- f. Mean top surface temperature.
- g. A report of the visual observations including displacement of metal cladding on the underside, burning or melting of any of the constituent materials of the panels or supporting structure.
- h. A statement that the test results of this system are indicative only.

T41a.00 | Thermal Properties

(Partial Access Systems)

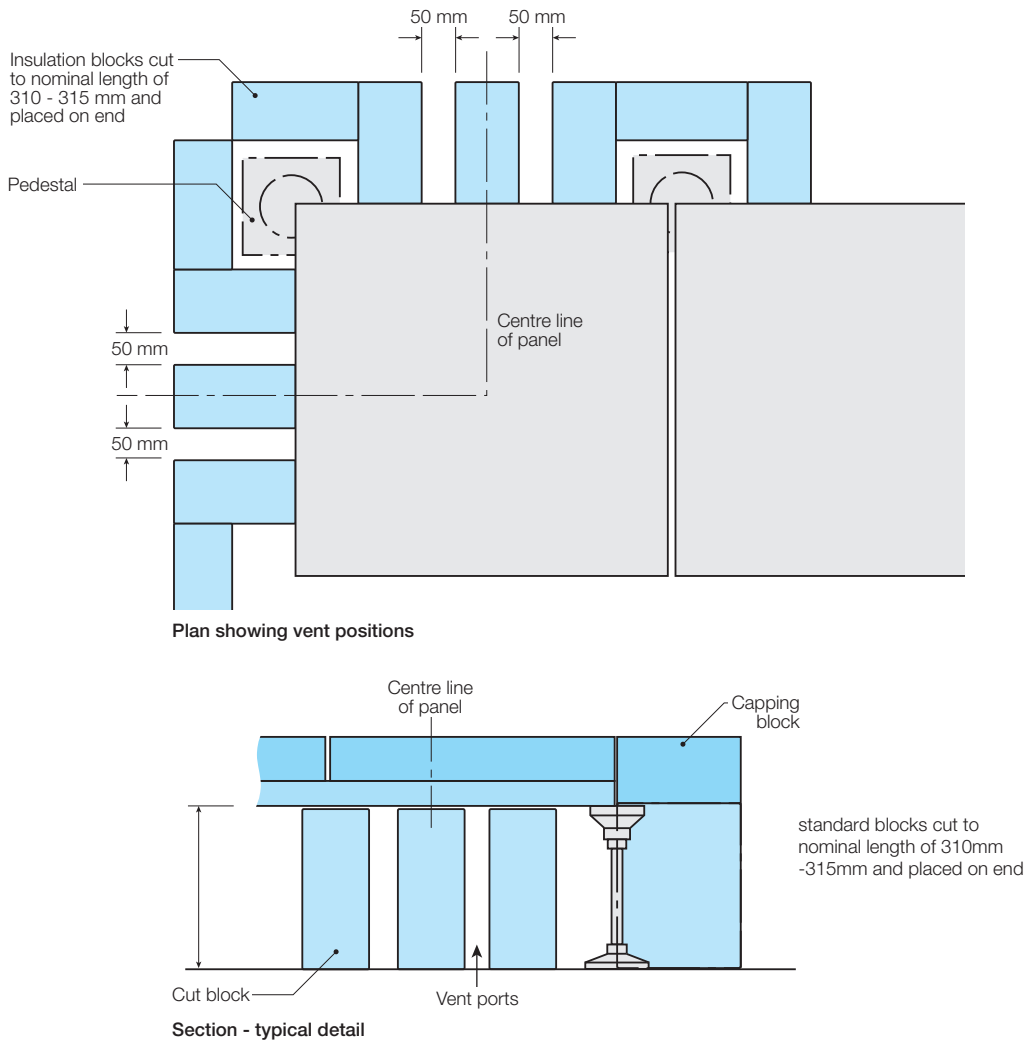
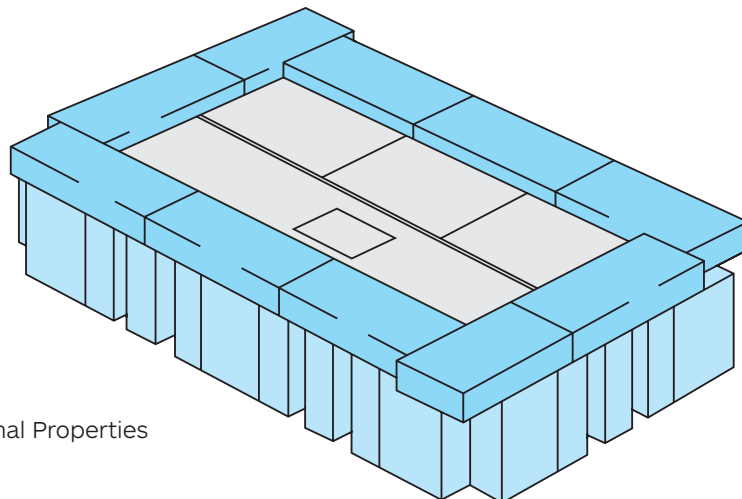

Figure 33 Thermal Properties



T42.00 | Pedestal Structure & Fixings Test

The dynamic impact test shall be carried out on site by the supplier and witnessed by the nominated officer of the Authority, on a random sample of installed free-standing pedestals and on a single free-standing pedestal as may be required by clause P4.06. P4.06

The test shall be carried out as follows:

A soft body comprising a canvas/leather bag 150mm dia. x 250mm containing dry sand and weighing 3 kg shall be arranged to swing through an arc of 90 degrees at a radius of 1 metre to strike the head of the selected pedestal. See Figure 35.

When subjected to this dynamic force, the pedestal structure shall not fail, and the pedestal shall remain firmly fixed to the sub floor.

The test shall not be commenced until at least 48 hours have elapsed from the time that any adhesives, used to install the pedestals, were first applied.

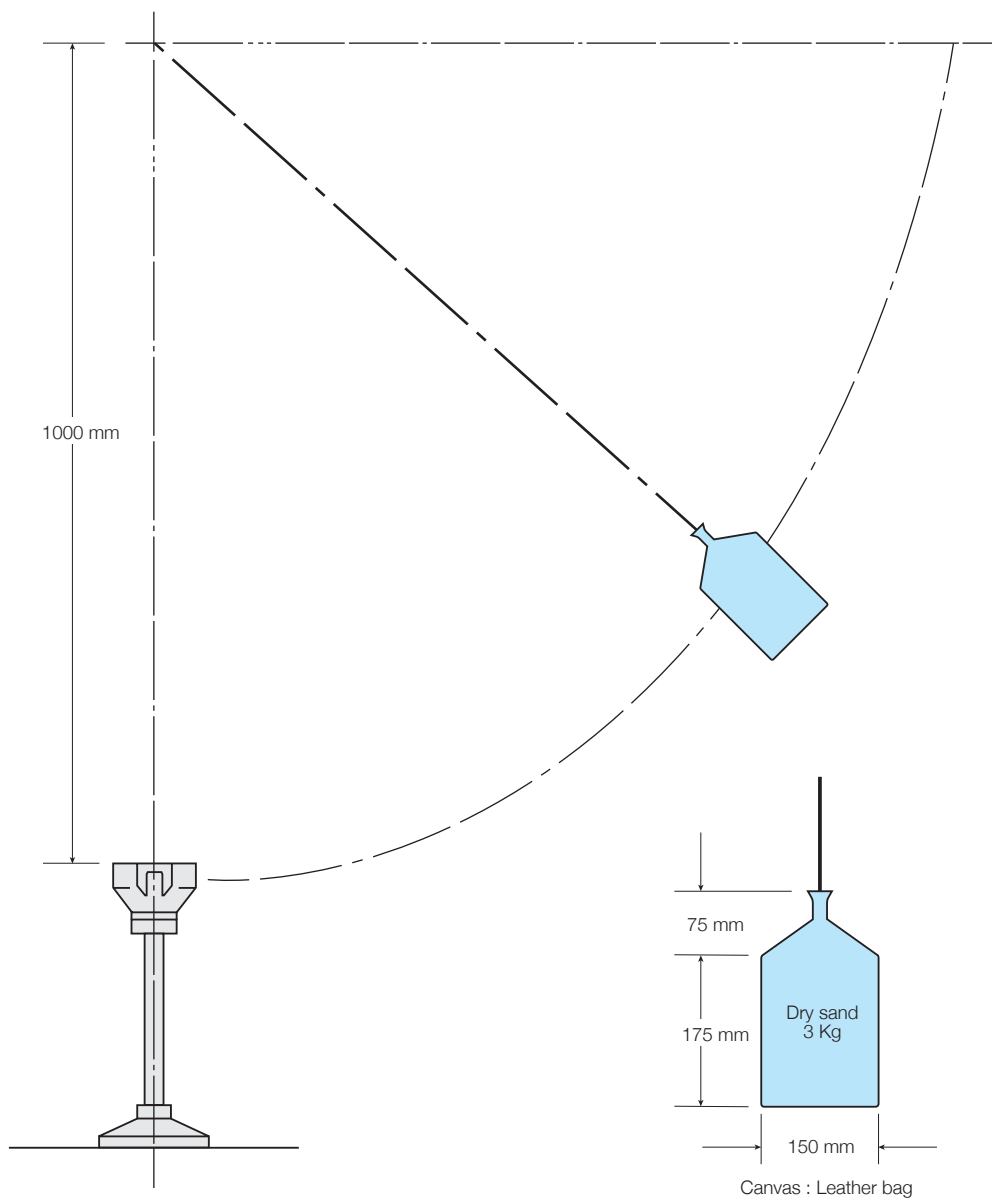

Figure 35 Pedestal Structure and Fixing Test

T43.00 | Electrical Resistance Test for Electrostatic Control

When required, the supplier shall arrange for a test to be carried out on the complete system (including the floor covering where applicable) on site and witnessed by a nominated officer of the Authority to verify the electrostatic performance requirement stated in Clause P9.01 of this document. The test shall be carried out as follows:

P9.01

- a. The test instrument shall be capable of measuring resistance values in the range 1×10^4 to 2×10^{12} ohms and shall have a rated voltage of 500 volts.
- b. A solid metal electrode having a mass of 4 kg and a contact area of 5000mm² shall be placed in contact with the floor surface.
- c. The floor area shall be divided into 2.4m x 2.4m squares and one test shall be carried out at the centre of each square.
- d. The resistance between the electrode and the building main earth terminal shall be measured and recorded.
- e. The test shall be carried out with the relative humidity stabilized at $50\% \pm 10\%$ for at least 48 hours.

T44.00 | Electrical Continuity Test

The supplier shall arrange for tests to be carried out on each platform floor system and for the tests to be witnessed by the nominated officer of the Authority, to verify the electrical continuity and earthing requirements specified in Clause P9.03.

P9.03

The tests that shall be carried out are as follows:

- a. The electrical continuity shall be measured from various distant points of the platform floor system and to the earth bar in the distribution board serving the area. The points chosen for the tests shall be a sample of all the various conductive components of the floor, i.e. the top and bottom of panels, pedestals, stringers etc., the number of points being sufficient to establish beyond reasonable doubt that the floor is electrically continuous.
- b. The test current shall be sufficient to give a reasonable indication of the probable electrical performance under fault conditions.
- c. The test instrument shall be of the type that provides a pulse of about 25 amps at a safe voltage for a safe duration and indicates a resistance in the range from 0 to 2 ohms and 0 to 20 ohms.
- d. The resistance of the measuring conductors shall be deducted from the test instrument readings.
- e. Each test reading shall be recorded and a copy of the complete test report, certified by the witnessing person, shall be forwarded to the nominated officer of the Authority.

APPENDIX A | Performance & Test Requirement for Accessories

1. Bar Type Air Grilles

This Requirement covers bar type air grilles which are identical in panel grid size to the floor system they are intended to fit.

The grilles shall be tested in accordance with the test methods detailed in the following test section.

The grilles shall sustain the relevant 25mm square concentrated loads detailed in Clause P4.01 at any position, for 24 hours and any deflection or deformation so caused, shall be stable within that period. Stability is deemed to be a maximum of 0.02mm difference in deflection between 23 and 24 hours after the test load was first applied. The loads applied shall not cause any permanent deformation of more than 0.75mm to the grille bars or frame which shall be measured 2 hours after removal of the load. The grilles shall also sustain a safety factor test of THREE times the particular 25mm square static loading for 5 minutes without collapse.

The grilles shall be capable of withstanding these loads at any of the positions which have been subjected to the particular static load test. The grilles shall be mounted on four steel blocks, each providing a support area of 40mm x 40mm at each corner and tested as detailed in test method A.

The grilles shall be subjected to a soft body impact safety test as detailed in the test method B and shall be capable of sustaining the test impact without collapse of the bars.

The grilles shall be capable of sustaining transient rolling loads across any area without the collapse or permanent deformation of the bars exceeding that stated in the table to this requirement. The loads shall be applied through a 150mm dia. x 40mm wide nylon wheel which shall traverse the upper surface of the grille at a velocity of 0.33 metres per second, (0.75 mph), as detailed in test method C. The wheel shall be as manufactured by Flexello, Type WNY6RBM20 or the equivalent, approved by the Authority."

Grade	Transient Rolling Load	Pass Criteria
Light & Medium	50 passes@ 2kN, in a direction parallel to the bars. 50 passes @2kN, in a direction at right angles to the bars. Followed by: 50 passes @3kN, in a direction parallel to the bars. 50 passes @3kN, in a direction at right angles to the bars.	Maximum permanent deformation: 4mm vertically 1mm horizontally Shall not collapse
Heavy & Extra Heavy	50 passes @3kN, in a direction parallel to the bars. 50 passes @3kN, in a direction at right angles to the bars. Followed by: 50 passes @4.5kN, in a direction parallel to the bars. 50 passes @4.5kN, in a direction	Maximum permanent deformation: 4mm vertically 1mm horizontally Shall not collapse

A.00 | Air Grille 25mm Square Static Load & Safety Factor Test

A.01

Test specimens

Four bar type air grilles which are identical in panel grid size to the floor system they are intended to fit.

A.02

Mounting for test

The specimens shall be mounted on steel blocks to provide support over an area of 40mm x 40mm at each corner.

A.03

Method of test

The indenter shall be a 25mm steel cube, the corners of which shall be rounded off to a radius of not more than 2mm.

The indenter shall be applied:

- a. To the centre of specimen one.
- b. To the centre of the edge of specimen two.
- c. To an adjacent centre of edge of specimen two.
- d. Any point on specimens three and four which the test authority may consider to be in an area of weakness.

A bedding-in load, consisting of the test load shall be applied and maintained for a period of 5 minutes and then released. An unloaded period of 5 minutes \pm 1 minute shall elapse before the commencement of the test and the zero deformation reading taken.

The particular static load specified in Clause P4.01 shall be applied and maintained for 24 hours at the centre of the indenter by means of a suitable test apparatus similar to that shown in Figure 7.

The deflection or deformation shall be measured directly below the indenter position and as near as possible to its centre position, to an accuracy of 0.01mm at:

- i. 23 hours; after application of the load,
- ii. 24 hours after application of the load and prior to its removal.

Residual deformation shall be measured 2 hours after load release.

The specimen shall then be subjected to a safety factor test consisting of THREE times the particular 25mm square static loadings at all test positions for 5 minutes during which time there shall be no collapse.

A.04

Test report

The test report shall include the following information:

- a. The full specification of the grille.
- b. A drawing of the grille to show the positions of the applied loads.
- c. The structural grade of the grille.
- d. The average environmental conditions over the period of the test.
- e. Deflection or deformation after 23 hours of loading.
- f. Deflection or deformation after 24 hours of loading.
- g. Difference between e and f (stability) - Maximum 0.02mm.
- h. The maximum permanent deformation 2 hours after the load was removed - Maximum permitted deformation 0.75mm.
- i. Any other damage to the grille.
- j. A statement that the grille DID or DID NOT collapse during Safety Factor loading.
- k. A statement that the grilles complied with the relevant performance requirements.

B.00 | Air Grille Soft Body Impact (Safety Test)

B.01

Test specimens

A bar type air grille identical in panel grid size to the floor system it is intended to fit.

B.02

Mounting for test

The specimen shall be mounted on steel blocks to provide support over an area of 40mm x 40mm at each corner.

B.03

Method of test

A canvas bag 600mm high with a 300mm dia. base containing dry sand to a mass of 40 kg. The filled bag shall be dropped on to the specimen from a height of 1 metre. The first drop shall make contact upon the centre of the specimen, the second drop shall make contact with the centre of one edge of the specimen and the third drop at an adjacent edge of the specimen, with the whole base of the bag coming into contact with the specimen.

The specimen shall not collapse on or after impact, but careful observation shall be made to determine whether any damage has occurred.

B.04

Test report

The test report shall include the following information:

- a. The full specification of the grille.
- b. The structural grade of the grille.
- c. The average environmental conditions over the period of the test.
- d. A statement that the grille DID or DID NOT collapse.
- e. A report of the collapse characteristic, if applicable, or of any other deformation.

C.00 | Air Grille Rolling Load Test

C.01

Test specimens

Two bar type air grilles which are identical in panel grid size to the floor system which they are intended to fit.

C.02

Mounting for test

Each specimen shall be mounted in a suitable test apparatus within a frame which will provide a 40mm x 40mm support at each corner.

A solid surface is required at each end on the same plane as the upper surface of the specimen, to provide a "run off" area for the test wheel.

The specimen shall be positioned such that the loaded test wheel will traverse across the specimen on paths considered by the test authority to be the weakest area. These paths shall be parallel to one side.

C.03

Method of test

A constant load equal to that specified in the performance section applicable to the particular structural grade under test shall be applied to a 150mm dia. x 40mm wide nylon wheel as "FLEXELLO" Type WNY6RBM20, or the equivalent, approved by the Authority.

The loaded wheel shall be made to traverse the specimen in alternate opposite direction for the requisite number of passes, i.e. 25 complete cycles will provide 50 passes, at a velocity of 0.33 metres per second (0.75 mph) across the selected path.

C.00 | Air Grille Rolling Load Test

For Light/Medium grade grilles:

- a. The wheel shall be loaded to 2kN and traverse specimen ONE for 25 complete cycles along a line parallel to the bar.
After 2 hours have elapsed the vertical and horizontal permanent deformation shall be measured.
The wheel shall next be loaded to 3kN and traverse along the same line for a further 25 complete cycles during which the specimen shall not collapse.
- b. The wheel shall be loaded to 2kN and traverse specimen TWO for 25 complete cycles along a line at right angles to the bars.
After 2 hours have elapsed the vertical and horizontal permanent deformation shall be measured.
The wheel shall next be loaded to 3kN and traverse along the same line for a further 25 complete cycles during which the specimen shall not collapse.

For Heavy/Extra heavy grilles

- a. The wheel shall be loaded to 3kN and traverse specimen ONE for 25 complete cycles along a line parallel to the bars.
After 2 hours have elapsed the vertical and horizontal permanent deformation shall be measured.
The wheel shall next be loaded to 4.5kN and traverse along the same line for a further 25 complete cycles during which the specimen shall not collapse.
- b. The wheel shall be loaded to 3kN and traverse specimen TWO for 25 complete cycles along a line at right angles to the bars.
After 2 hours have elapsed the vertical and horizontal permanent deformation shall be measured.
The wheel shall next be loaded to 4.5kN and traverse along the same line for a further 25 complete cycles during which the specimen shall not collapse.

All measurements shall be to an accuracy of 0.01mm.

C.04

Test report

The test report shall include the following information:

- a. A full specification of the grille.
- b. The structural grade of the grille.
- c. The average environmental conditions over the period of the test.
- d. Description or drawing of the test apparatus including the test wheel.
- e. A drawing showing the positions of the wheel tracks.
- f. The Extent and description of the permanent deformation. Maximum deformation for the selected grade, vertically and horizontally.
- g. A statement that the grille DID or DID NOT collapse.
- h. A description of any other damage or deformation to the grilles.
- i. A statement that the grille complied with the relevant performance requirements.

APPENDIX B | Project Particulars & Schedule of Performance Offer

This draft Appendix is intended for use when inviting tenders based upon the Performance Specification MOB PF2 PS /SPU. It is advisable that this is supplemented by an invitation to tender which defines requirements for return of tenders, site facilities and obligations and the Conditions of Contract which will apply.

Project Particulars

(For completion by the client's representative)

Name of Project

Site Location

Contract Drawings

Description of Works

The works comprise the design, supply and installation of platform (raised access) floors complying with Performance Specification MOB PF2 PS / SPU in locations indicated in the following schedule.

Platform floors are to be installed on

..... floors in rooms to be used for the purposes of

as indicated on the contract drawings. where more than one grade is specified the areas are referenced L (light), M (medium), H (heavy) or EH (extra heavy) and the contract drawings are hatched or coloured to indicate location of each grade.

Other Items

.....

.....

.....

APPENDIX B | Project Particulars & Schedule of Performance Offer

Platform Floors: Schedule of Performance Offer

(To be completed by the Tenderer)

Name of Supplier

Name of Manufacturer
(If different from supplier)

System Name	Location A	Location B	Performance Specification Reference
1. Type full access or partial access			P2.01
2. Structural Grade light, medium, heavy or extra heavy			P2.02
3. With or without stringers bolted or clip-in			P2.01
4. Accessories offered			P2.05
Full Access Systems			
5. Co-coordinating size of panels			P3.05(a)
6. Weight of panels			P3.05(a)
7. Panel location method			P3.02
8. Dimensional grid of pedestals			P3.05(a)
9. Maximum height of system design height			P3.05(a)
10. Minimum height of system design height			P3.05(a)
11. Are cross bracings required and what height?			P3.05(a)
12. Limitation of adjustability on design heights			P3.05(a)
13. Thermal properties			P6.08
Partial Access Systems			
14. Size of panels			P3.05(b)
15. Dimensional grid of pedestals			P3.05(b)
16. Size of removable panels (access panels)			P3.05(b)
17. Weight of removable panels			P3.05(b)
18. Maximum height of system Design height			P3.05(b)
19. Minimum height of system Design height			P3.05(b)
20. Limitation of adjustability on Design height			P3.05(b)
21. Thermal properties			P6.08

APPENDIX B | Project Particulars & Schedule of Performance Offer

System Name	Location A	Location B	Performance Specification Reference
All Systems			
22. Details of panel materials			P2.03
23. Details of pedestal materials and assembly			P2.03
24. Details of stringer materials and assembly (if applicable)			P2.03
25. Size of pedestal base			P4.06
26. Method of pedestal fixing (type of adhesive and mechanical fixing used)			P4.06
27. Sub floor finish required			P4.06
28. Detail of pedestal adjustment			P3.07 and P4.07
29. Detail of adjustment locking			P4.07
30. Detail of perimeter support			P3.06 and P4.08
31. Weight of system per M ²			P4.11
32. Movement under stated hydrothermal conditions	a. b. c. d.		P5.01
33. Details of cavity barriers			P6.06
34. Types of floor covering offered			P2.06 and P8.00
35. Expected minimum life of:			
The complete system			P11.01
The supporting system			
The panels			
The floor covering			
Any other replaceable component			
36. Minimum maintenance free life of the whole system			P11.01
37. Recommended period of maintenance			P11.01
38. The minimum maintenance-free life of any replaceable part, where this is different from the whole of the system			P11.01
39. Period that replaceable parts will be available			P11.01
40. Air plenum systems Maximum design pressure (Note 1) Air leakage rate			

APPENDIX B | Project Particulars & Schedule of Performance Offer

All Systems - continued

System Name	Location A	Location B	Performance Specification Reference
41. Details of protective finishes			P11.02
42. Details of requirement for underfloor sealing (Note 1)			
43. Test evidence			P14.00
44. Installation instructions (including COSHH Statement)			P4.06 and P2.03
45. Compliance			P6.01
BS6266: 2011			
Quality management system to BS EN ISO 9001:2015			P0.04
BS5750 - 1987			
Part I Design			

Note 1: To be completed by specifier

Guidance Notes for Users

1 The Method of Building (MOB) Performance Specification for Platform Floors has become recognised as the industry standard in the UK and is being followed by other countries as well.

2 If reference is made to this specification MOB/PF2 PS/SPU in contract or sub-contract tender documents specifiers can save time otherwise required to draft ad hoc specifications and suppliers can readily offer standard products.

3 Should specifiers wish to exclude any clauses then it is recommended that these should be listed in the invitation to tender.

4 Particular attention is drawn to:

PO.04 Quality Assurance

This clause requires independent certification of the supplier's quality management system to BS EN ISO 9001: 2015. The Invitation to tender should indicate whether the specifier is prepared to accept an alternative form of Quality Assurance.

P3.05 Shape:Grid:Dimension:Weight

Provide details of sub-floor, including levels, in project tender documents.

5 APPENDIX B Project Particulars and Schedule of Performance Offer

This draft appendix is intended as the technical support document to an invitation to tender. The specifier should complete the project particulars on Sheet 1 and Item 4.2 on Sheet 4 before issue to tenderers for completion of sheets 2.3 and 4; floor covering requirements may be indicated by the specifier as "other items". In addition to the coverings listed at P8.05 and P8.03 other options such as stone, marble, terrazzo, timber and carpet tiles of various constructions are becoming available. Advice should be sought from potential suppliers.

It is important that the scope and location of Platform Floors are indicated on drawings and where more than one grade is specified their application is clearly shown. If more than two grades are specified, the Appendix may be duplicated and further references (eg C and D) added to column headings.

The completed Appendices returned by tenderers, supported by test evidence, provides specifiers with a basis of tender assessment and evaluation.

Sheet 4 of 4

